

Trapezoid Base for Steady Knuckle Feet

Steady knuckle foot for levelling out uneven floors.

Material: Die-cast zinc with a black powder coat

Matching threaded rod: Threaded rod for steady knuckle feet for levelling

System: 40 - Slot 8; 30 - Slot 6; 20 - Slot 5

Type: Feet



General Data

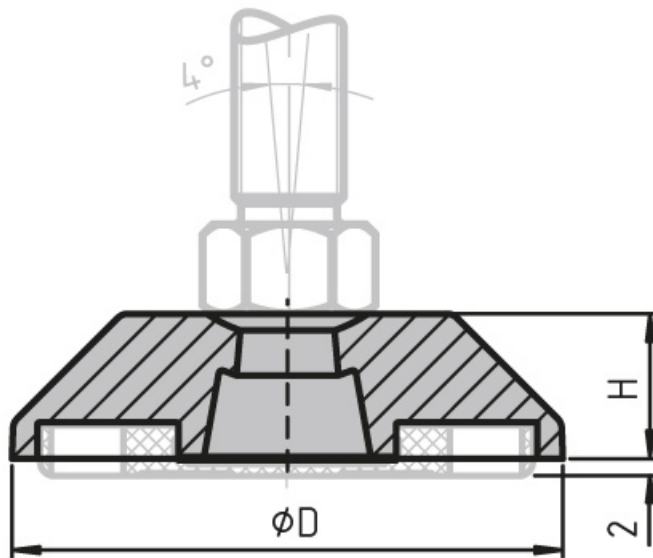

Designation	Description	D	H	Carrying Capacity (kg)	Size
PZ5223	Trapezoid base for steady knuckle feet	59	18	2500	60
PZ5224	Trapezoid base for steady knuckle feet with anti-slip plate	59	18	2500	60
PZ5225	Trapezoid base for steady knuckle feet	76	20	3000	80
PZ5226	Trapezoid base for steady knuckle feet with anti-slip plate	76	20	3000	80