

PSW 33 - Shaft 14 mm hollow

- Positioning system with IP 68
- Absolute measuring system, without battery
- Galvanically separated supply voltages between control and motor and bus
- Absolute encoder eliminates the need for reference runs during system setup and installation of replacements
- Easy address assignment directly on the device using integrated address switches (not for IO-Link)
- Manual disconnecting lever permits manual disconnection of the gearbox
- Regulation of the current torque prevents overloading and unnecessary run aborts
- Strong breakaway torque enables safe start-up even after an extended standstill
- Intelligent running behaviour. Recognises the difference between obstacles and dirt
- Spindle offset run: Excludes inconsistencies due to lash in the spindle
- Condition monitoring of supply voltage, drag error (permits optimum adjustment of current position), power consumption and torque
- Partial safety function for STO (Safe Torque Off)



Dimensions in mm.

Type: Vertical

Nominal Voltage (V DC): 24 ($\pm 10\%$)

Nominal Current (A): 3.1

Output Shaft (mm): 14

Output Shaft Type: Hollow

BUS Communication: Can Open (CA); Profi Bus (DP); Device Net (DN); Modbus (MB); IO-Link (IO); ProfiNet (PN); Sercos (SE); EtherCat (EC); Ethernet IP (EI); PowerLink (PL)

Electrical connection: "Standard; with jog keys; 1 connector Y-encoded or 1 connector Y-encoded with jog keys"

Protection Class: IP68

Motor: EC-motor

Supply Voltage: 24 V DC $\pm 10\%$ galvanically separated between control and motor and bus

Measurement System: Absolute, optical-magnetic

Accuracy: $\pm 0.9^\circ$

Intermittence: 20% (basis time 600 s)

Manual Adjustment: Standard

Brake: Optional (holding brake)

Material: All components in stainless steel. (Except for feather key, if available.)

Performance Curve - Direct Drives PSW



General Data

viewing window and access to address switch and status display

cover, manual adjustment beneath

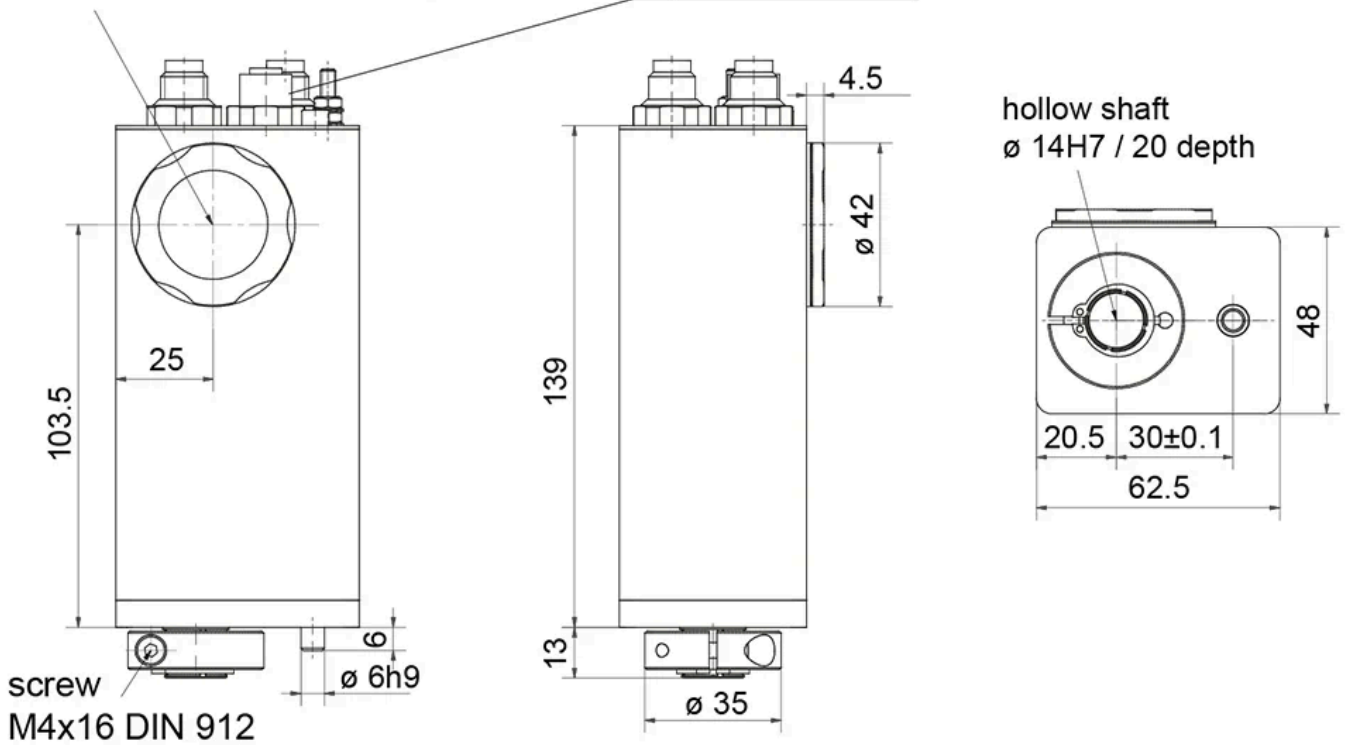

Designation	Nominal Torque (Nm)	Nominal Speed (rpm)	Nominal Current (A)	Self-holding Torque (Nm)	Positioning Range (rot.)
PSW 332-14H	2	125	3.1	1	250
PSW 335-14H	5	50	3.1	2.5	250