

## PSS 32 - Shaft 14 mm solid

- Positioning system with IP 65
- Absolute measuring system, without battery
- Galvanically separated supply voltages between control and motor and bus
- Absolute encoder eliminates the need for reference runs during system setup and installation of replacements
- Easy address assignment directly on the device using integrated address switches (not for IO-Link)
- Manual disconnecting lever permits manual disconnection of the gearbox
- Regulation of the current torque prevents overloading and unnecessary run aborts
- Strong breakaway torque enables safe start-up even after an extended standstill
- Intelligent running behaviour. Recognises the difference between obstacles and dirt
- Spindle offset run: Excludes inconsistencies due to lash in the spindle
- Condition monitoring of supply voltage, drag error (permits optimum adjustment of current position), power consumption and torque
- Partial safety function for STO (Safe Torque Off)



Dimensions in mm.

Contact us for CAD-files.

**Type:** Horizontal

**Nominal Torque (Nm):** 2; 5

**Nominal Speed (rpm):** 68; 150

**Nominal Voltage (V DC):** 24 ( $\pm 10\%$ )

**Nominal Current (A):** 3.1

**Output Shaft (mm):** 14

**Output Shaft Type:** Solid

**BUS Communication:** Can Open (CA); Profi Bus (DP); Device Net (DN); Modbus (MB); IO-Link (IO); ProfiNet (PN); Sercos (SE); EtherCat (EC); Ethernet IP (EI); PowerLink (PL)

**Electrical connection:** "Standard; with jog keys; 1 connector Y-encoded or 1 connector Y-encoded with jog keys"

**Protection Class:** IP65

**Motor:** EC-motor

**Supply Voltage:** 24 V DC  $\pm 10\%$  galvanically separated between control and motor and bus

**Measurement System:** Absolute, optical-magnetic

**Accuracy:**  $\pm 0.9^\circ$

**Intermittence:** 20% (basis time 600 s)

**Manual Adjustment:** Standard

**Brake:** Optional (holding brake)

**Material:** Stainless steel housing. See pdf for details.

# PSS 32 - Shaft 14 mm solid

Performance Curve - Direct Drives PSS

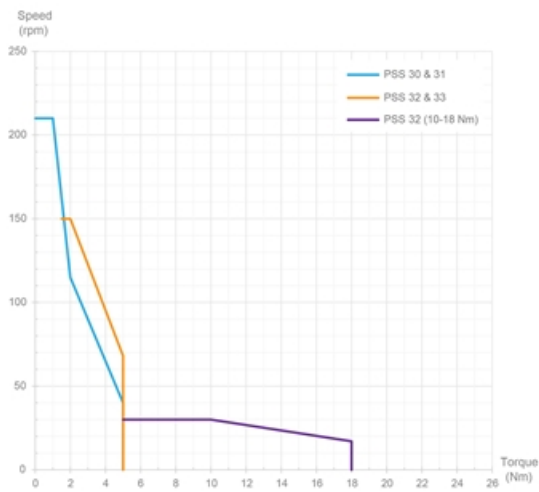

## General Data

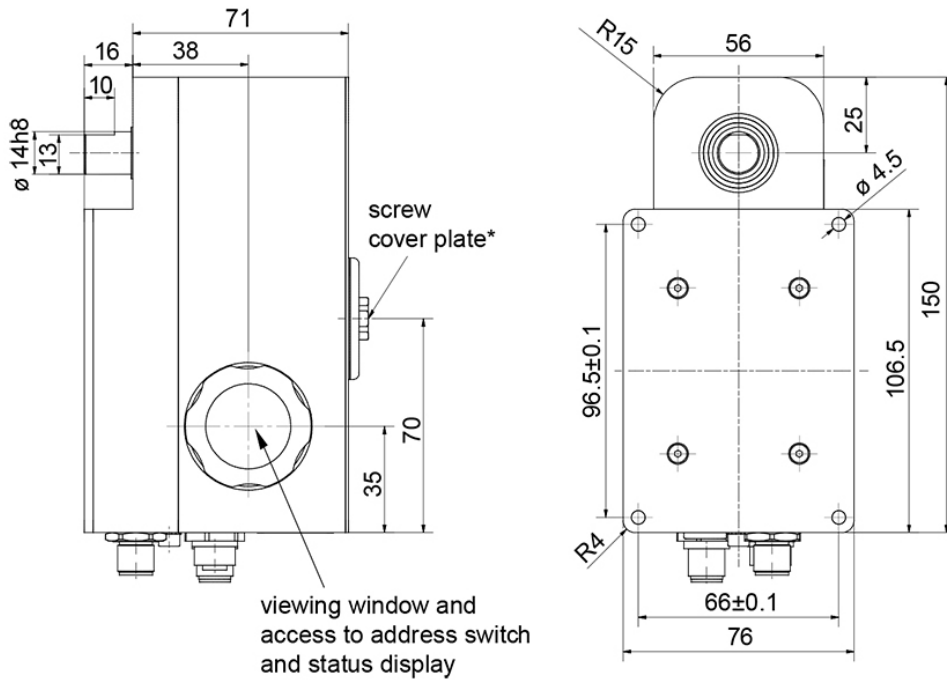

\* over a rotating manual adjustment shaft SW 6/8 depth hex

Designation	Nominal Torque (Nm)	Nominal Speed (rpm)	Nominal Current (A)	Self-holding Torque (Nm)	Positioning Range (rot.)
PSS 322-14V	2	150	3.1	1	250
PSS 325-14V	5	68	3.1	2.5	250