

BR---.4100

- The fixing element is welded with the respective combined roller.

Dimensions in mm.

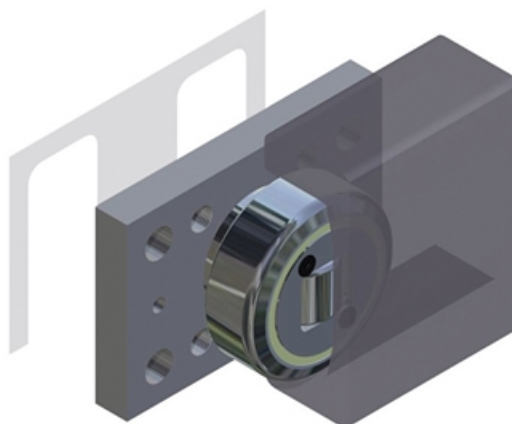

General Data

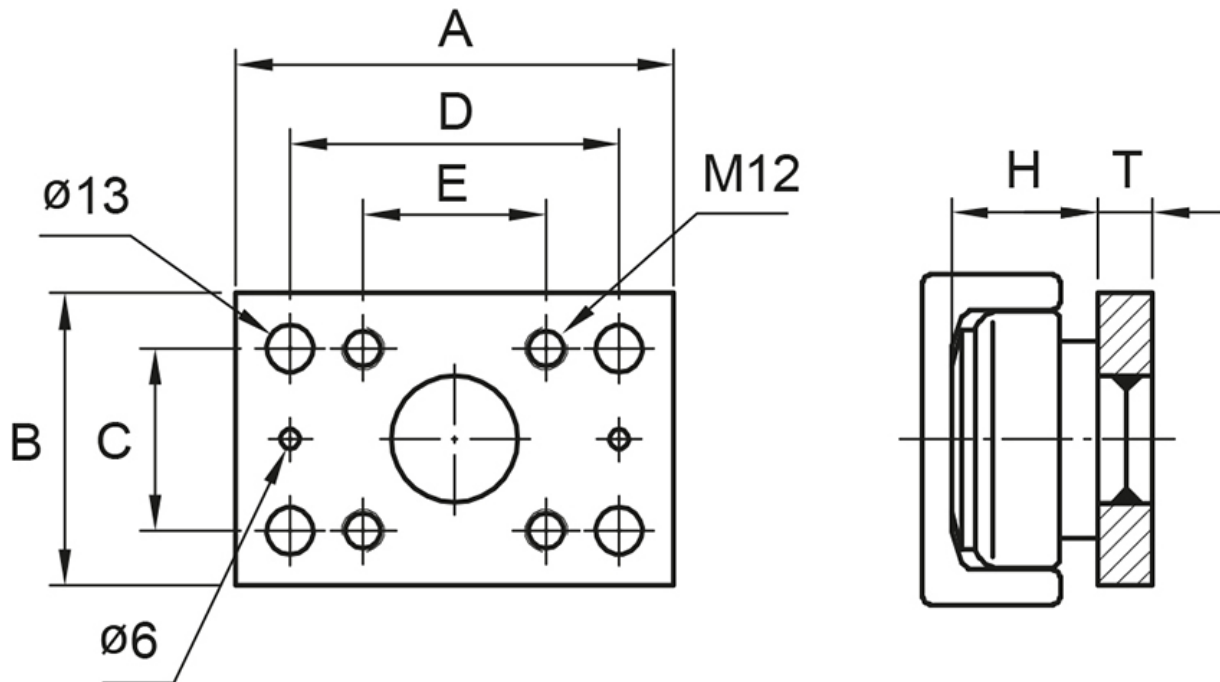

Designation	A	B	H	D	C
70-BR4100	120	80	40	90	50
80-BR4100	120	80	39.5	60	50

Designation	T	E	Remark
70-BR4100	15	50	Roller: TR070.0390
80-BR4100	15	50	Roller: TR080.0390