

Table of contents

- **Flanged Block Type FNS**
- **Narrow Block Type GNS**
- **Rail Type A**
- **Rail Type B**
- **Clamping Element**
- **Seal Unit**
- **Lube Unit with Sealing Function**
- **RA Grease**

Flanged Block Type FNS

This light-weight flanged runner block is designed for cost-effective applications such as assembly and handling processes. Mounting dimensions are identical to those of the steel guiding rails and in accordance to DIN 645-1, which makes them interchangeable and replaceable.

The runner block has a lateral abutment edge and can then be screwed from above or below. Runner block consists of an aluminium alloy with a tensile strength of 350N/mm², balls and running tracks of hardened stainless steel, X46Cr13 (1.4034). All others parts are made of POM. The carriage is pre-lubricated and has standard seal units, which can be replaced.

Note!

Determination of the dynamic load capacities and torques is based on a travel life of 100.000 m. Due to the mechanical operations of guide rails and runner block with their different materials, is not possible to clearly indicate a static load rating. In this case never exceed Max permissible load or Static moment M_{r0} . Otherwise malfunction or damage may occur.

See technical information regarding Lube units.

Dimensions in mm.

Lead times in the table below are only indications. Choice of options will affect lead time. Please contact us for exact delivery time for your request.

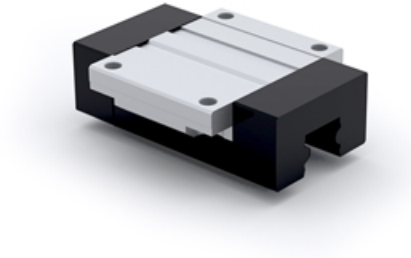

General Data

Dynamic load capacity

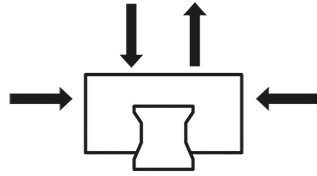

Moment

M_r / M_{r0}

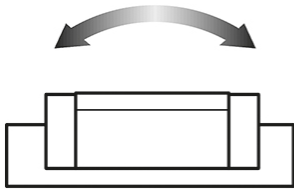

M_p / M_{p0}

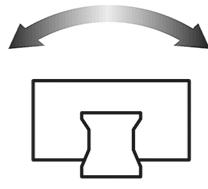

M_y / M_{y0}

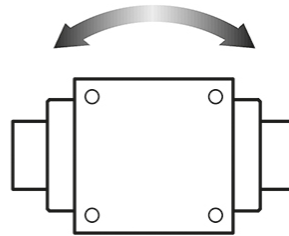

Designation	Dynamic Load Capacity C (N)	Static Moment M_{r0} (Nm)	Static Moment M_{p0} (Nm)	Static Moment M_{y0} (Nm)	Dynamic Moment M_r (Nm)
FNS15	5000	14	12	12	36
FNS20	11000	40	35	35	101
FNS25	16000	66	59	59	165

Designation	Dynamic Moment M_p (Nm)	Dynamic Moment M_y (Nm)	Weight Block (kg)	Max. Permissible Load F_{max} (N)
FNS15	29	29	0.08	2000
FNS20	89	89	0.18	4400
FNS25	147	147	0.26	6400

Dimensions

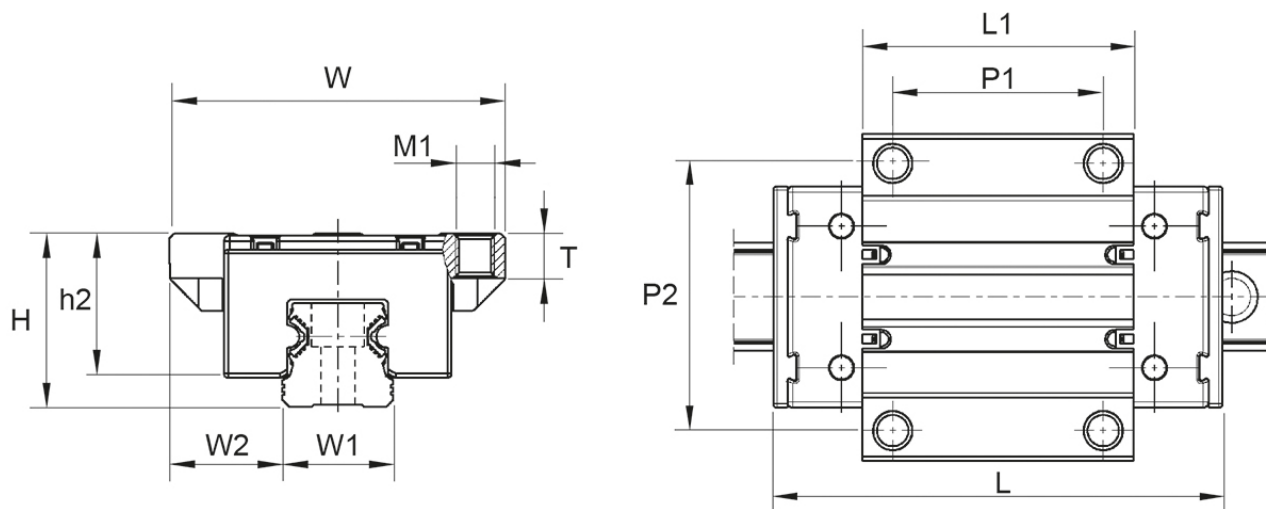

Designation	L	H	W	L1	h2	W1	W2	T	M1
FNS15	64	24	47	37.8	19.8	15	16	6	M5
FNS20	85.9	30	63	51.5	24.7	20	21.5	8	M6
FNS25	96	36	70	58	29.9	23	23.5	9.3	M8

Designation	P1	P2
FNS15	30	38
FNS20	40	53
FNS25	45	57

Narrow Block Type GNS

This light-weight narrow runner block corresponds to the structure of the flanged runner block from the previous page. It's only slimmer and designed for mounting from above. The mounting dimensions are also identical to the steel guiding rails and in accordance to DIN 645-1. In this way you can easily change the installed constructions.

Note!

Determination of the dynamic load capacities and torques is based on a travel life of 100.000 m. Due to the mechanical operations of guide rails and runner block with their different materials, is not possible to clearly indicate a static load rating. In this case never exceed Max permissible load or Static moment M_{r0} . Otherwise malfunction or damage may occur.

See technical information regarding Lube units.

Dimensions in mm.

Lead times in the table below are only indications. Choice of options will affect lead time. Please contact us for exact delivery time for your request.

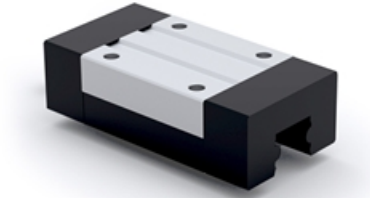

General Data

Dynamic load capacity

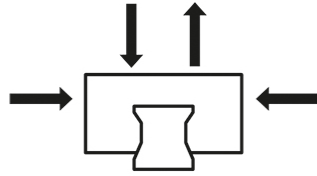

Moment

M_r / M_{r0}

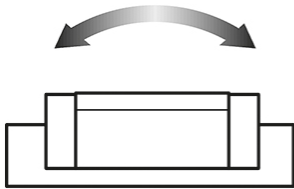

M_p / M_{p0}

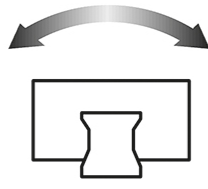

M_y / M_{y0}

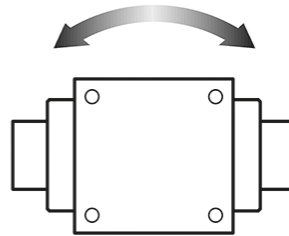

Designation	Dynamic Load Capacity C (N)	Static Moment M_{r0} (Nm)	Static Moment M_{p0} (Nm)	Static Moment M_{y0} (Nm)	Dynamic Moment M_r (Nm)
GNS15	5000	14	12	12	36
GNS20	11000	40	35	35	101
GNS25	16000	66	59	59	165

Designation	Dynamic Moment M_p (Nm)	Dynamic Moment M_y (Nm)	Weight Block (kg)	Max. Permissible Load F_{max} (N)
GNS15	29	29	0.07	2000
GNS20	89	89	0.15	4400
GNS25	147	147	0.22	6400

Dimensions

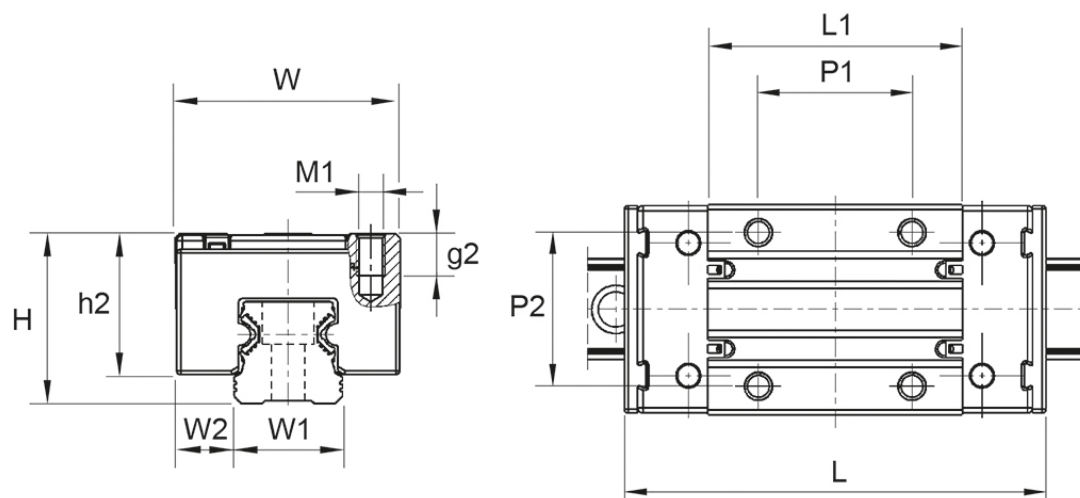

Designation	L	H	W	L1	h2	W1	W2	T	M1
GNS15	64	24	34	37.8	19.8	15	9.5	-	M4
GNS20	85.9	30	44	51.5	24.7	20	12	7.5	M5
GNS25	96	36	48	58	29.9	23	12.5	9	M6

Designation	g2	P1	P2
GNS15	6	26	26
GNS20	-	36	32
GNS25	-	35	35

Rail Type A

Corrosion resistant profiled rail, counterbore from above.

The aluminium profile rails are made of high quality aluminium alloy with rolled and precisely calibrated raceways made of stainless steel, X46Cr13 (1.4034) and are produced only in the accuracy class P. The use of aluminium achieves a weight saving compared to the steel types. It better compensates any unevenness in the mounting surface. The use of stainless steel for the track material, makes the rail corrosion resistant.

Due to the aluminium/steel composite construction, the rails should get ordered in the correct length. Only in exceptional cases it is allowed to cut it by yourself. Please insert rail lengths in mm after the designation when ordering. For example: A20-820.

Dimensions in mm.

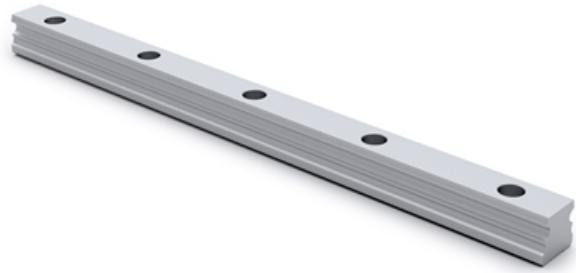

General Data

Designation	Weight Rail (kg/m)	Length (mm)
A15-...*	0.57	4000
A20-...*	0.98	4000
A25-...*	1.25	4000

Dimensions

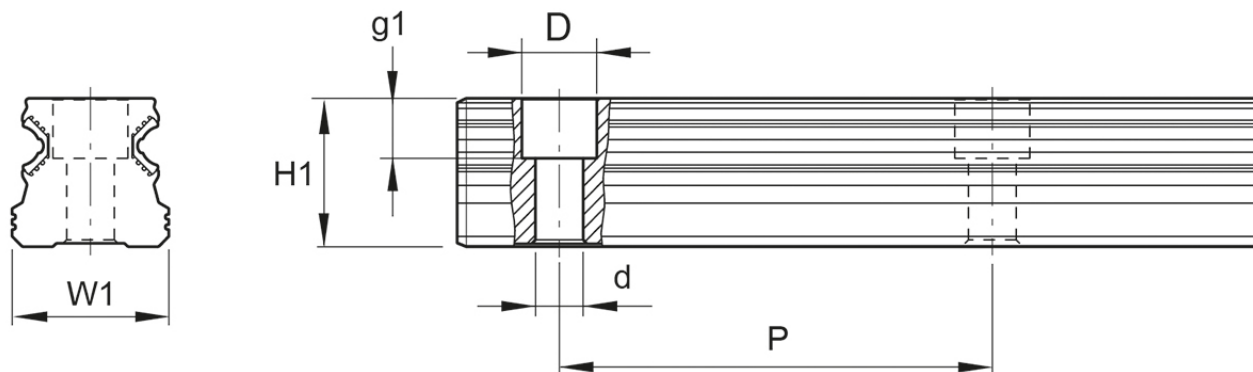

Designation	H1	W1	D x d x g1	Hole Pitch (P)
A15-...*	14	15	7.5 x 4.4 x 5.9	60
A20-...*	19	20	9.5 x 6 x 7.4	60
A25-...*	21.8	23	11 x 7 x 8.9	60

Rail Type B

Corrosion resistant profiled rail, tapped from bottom.

The aluminium profile rails are made of high quality aluminium alloy with rolled and precisely calibrated raceways made of stainless steel, X46Cr13 (1.4034) and are produced only in the accuracy class P. The use of aluminium achieves a weight saving compared to the steel types. It better compensates any unevenness in the mounting surface. The use of stainless steel for the track material, makes the rail corrosion resistant.

Due to the aluminium/steel composite construction, the rails should get ordered in the correct length. Only in exceptional cases it is allowed to cut it by yourself. Please insert rail lengths in mm after the designation when ordering. For example: B20-820.

Dimensions in mm.

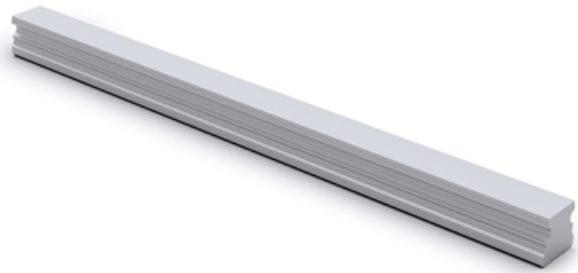

General Data

Designation	Weight Rail (kg/m)	Length (mm)
B15-...*	0.57	4000
B20-...*	0.95	4000
B25-...*	1.25	4000

Dimensions

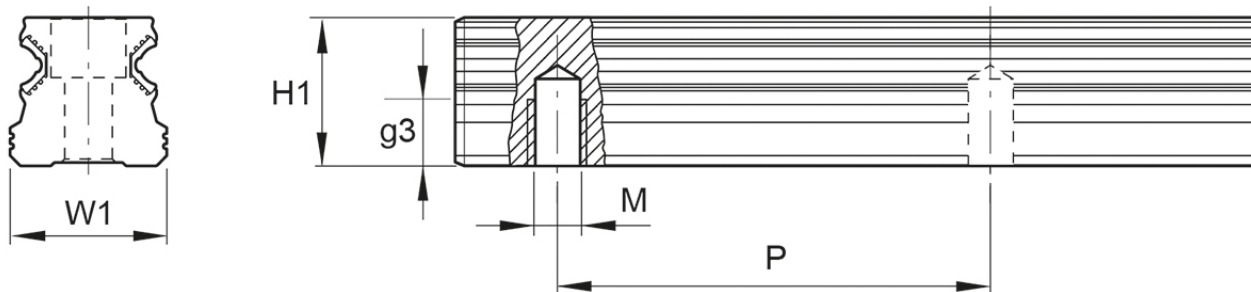

Designation	H1	W1	M x g3	Hole Pitch (P)
B15-...*	14	15	M5 x 7	60
B20-...*	19	20	M6 x 9	60
B25-...*	21.8	23	M6 x 12	60

Clamping Element

The manual clamping unit dHK is made of aluminium and plastic.

It fits on both type of rails (A and B).

Compatible with Linear Rail Aluminium only.

Dimensions in mm.



General Data

Designation	Compatible with	Holding Force (N)	Tightening Torque (Nm)
dHK15	A15-...*, B15-...*	130	3
dHK20	A20-...*, B20-...*	250	3
dHK25	A25-...*, B25-...*	330	3

Dimensions

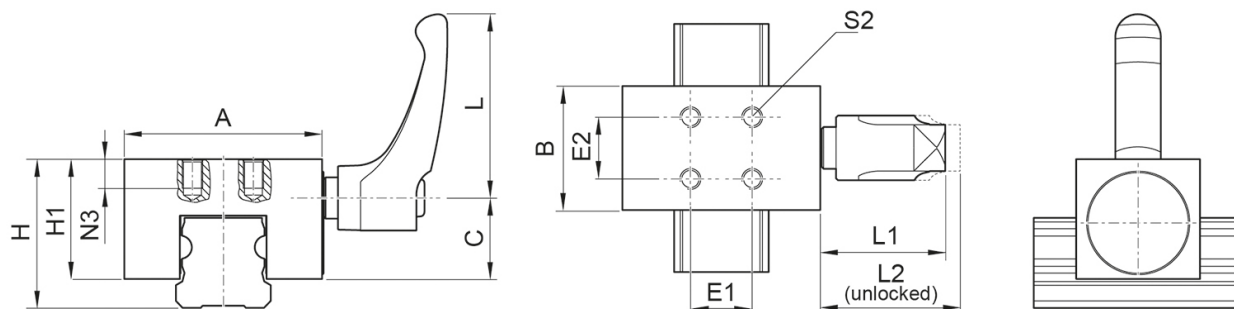

Designation	L	H	L1	L2	H1	S2	A	B	C
dHK15	40	24	29.9	33.3	19.8	M3	34	20	12.9
dHK20	40	30	29.9	33.4	24	M4	44	24	16
dHK25	44	36	29.8	33.3	29	M5	48	30	19.6

Designation	N3	E1	E2
dHK15	6	10	10
dHK20	6	12	12
dHK25	7	15	15

Seal Unit

All runner blocks are delivered with greased seal units. The basic material is POM.

Instructions for the replacement:

- Pull exchanged seal unit up.
- Insert the new seal unit.
- Push the runner block back on the guide rail.
- Align the seal unit vertically to the guide rail.

Note! Assembly with mounted carriage is not possible.

Dimensions in mm.



Dimensions

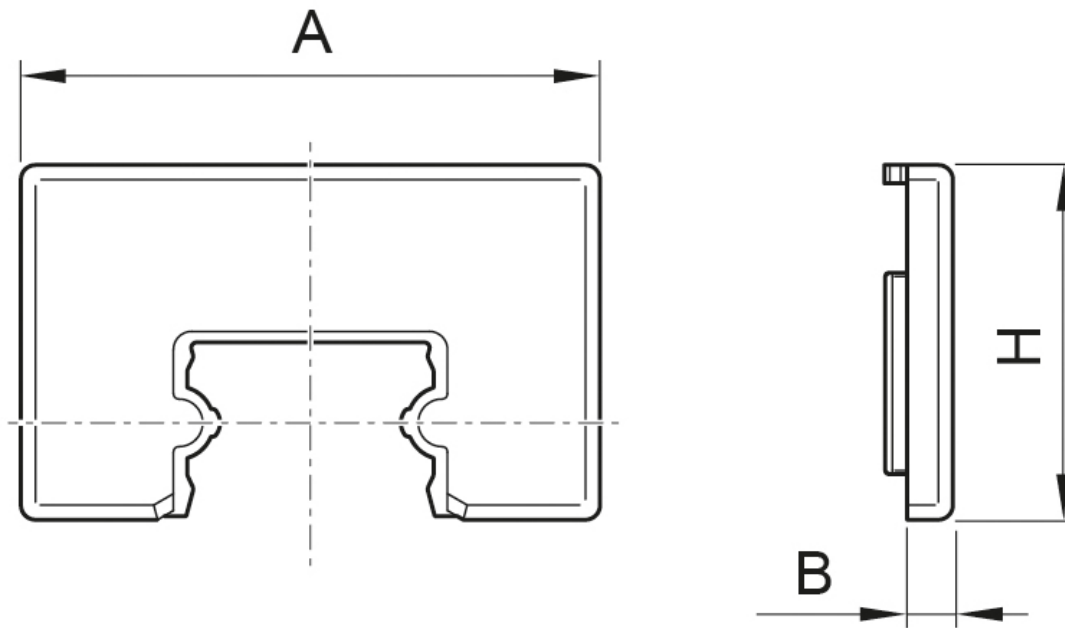

Designation	A	B	H
nVA15	31.7	2.5	19.4
nVA20	43.2	2.8	24.3
nVA25	47.2	3	26.3

Lube Unit with Sealing Function

Lube units with sealing function are used in applications with higher mileage or in dirty environments. Located inside the blocks and impregnated with oil ISO VG100, they ensure a continuous lubrication and simultaneously act as front seals. Due to this a service life of 12500 km is possible, without further lubrication. After it is possible to lubricate via the lubrication oil connections or the enclosed grease nipple. Optimally is when you replace the whole unit. The lube units are simply pushed over the rail and mounted by the attached bayonet fittings at the front side of the runner block, when the existing seal unit is removed.

Dimensions in mm.



General Data

Designation	Remark	Lubrication
dsF15	Supplied grease nipple nSN-00M3	Oil 0.65 cm ³
dsF20	Supplied grease nipplenGN-00M6	Oil 1.35 cm ³
dsF25	Supplied grease nipple nGN-00M6	Oil 1.7 cm ³

Dimensions

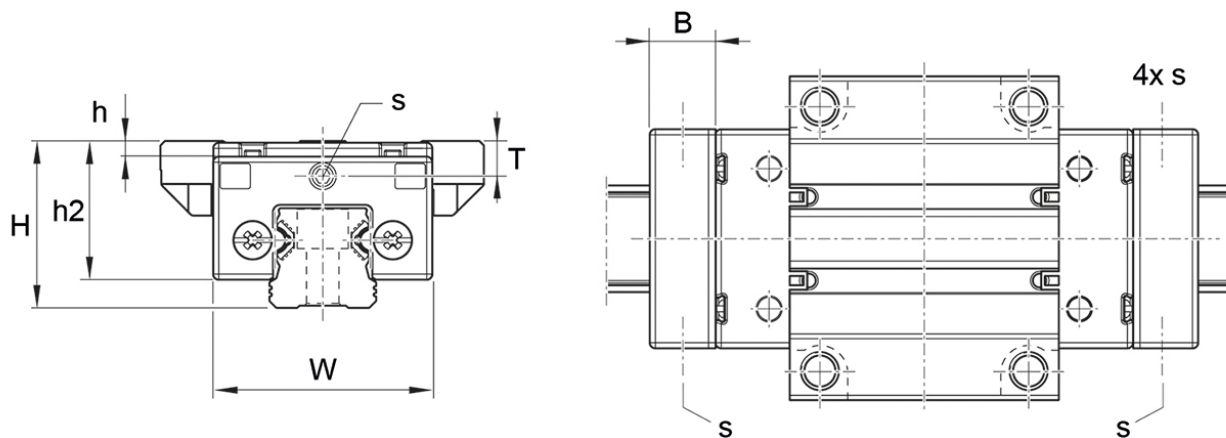

Designation	H	W	h	h2	B	S	T
dsF15	24	31.7	0.4	19.4	11.5	M3	4.5
dsF20	30	43.2	0.4	24.3	15.5	M6	5
dsF25	36	47.2	3.4	30	17.2	M6	7.6

RA Grease

NLGI grade 1.5

Clear grease based on synthetic oils and PTFE. Will fulfil all severe specifications from bearing manufacturers, industrial applications and vehicle producers. Very suitable for use where long service life is required and desired. The specific rheological properties of the lubricant will give very low good flow properties of the grease at extremely low temperatures, at the same time the high film strength and thickness will guarantee lubrication also at elevated temperatures. The type of PTFE used will adhere strongly to all surfaces lubricated and give a very low friction coefficient. The grease is water resistant, withstands oxidation, has very good mechanical stability, is completely non-toxic and provides a very wide application temperature range.

Temperature: -40 to +260 °C (application range)



General Data

Designation	Remark	Colour	Weight (g)
RA Grease NLGI 1.5	Cartridge package	Translucent white	400 g