

Conveyor Stand TB80 Multisystem

Aluminium profile stand to match Rollco Timing belt conveyors. Available with adjustable fixable feet. Configure your stand together with the timing belt conveyor in our CAD-configurator.

Values shown under "General data" indicates min and max values in mm according to our standard configurations. For other designs, please contact Rollco.



General Data

Stand TB80 Multi Timing Belt Conveyor
 $535 \leq E, D < 600$

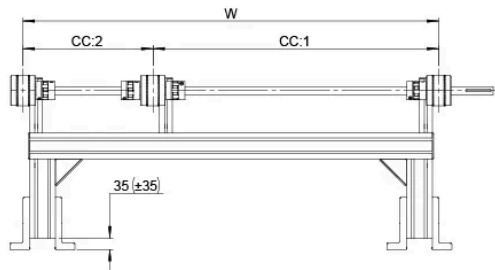
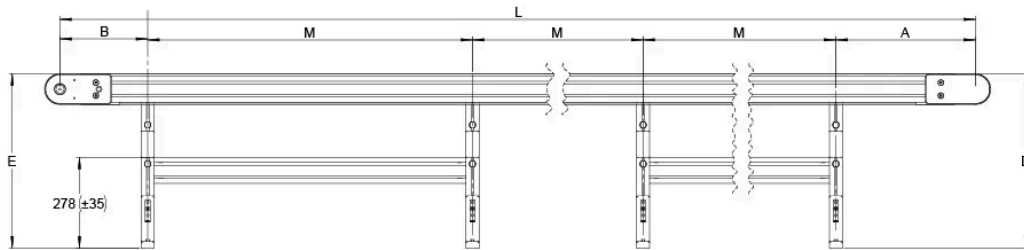

Stand TB80 Multi Timing Belt Conveyor
 $600 \leq E, D \leq 900$

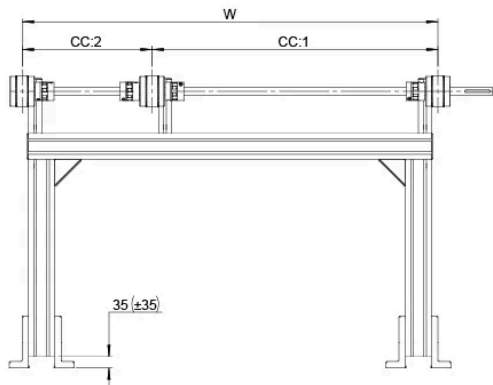
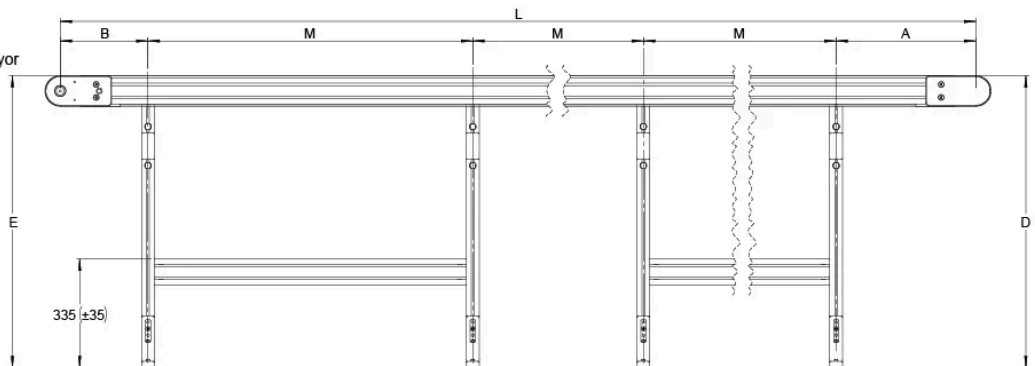

Stand TB80 Multi Timing Belt Conveyor
900 < E,D ≤ 1200

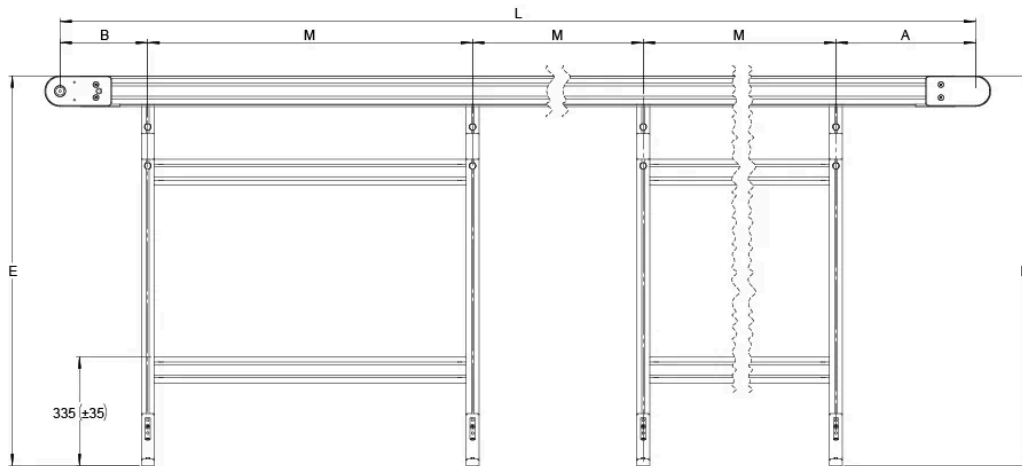

Stand TB80 Multi Timing Belt Conveyor
900 < E,D ≤ 1200

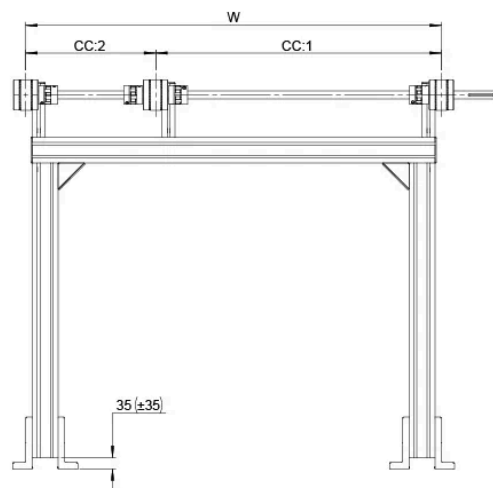

Designation	Profile Width	Profile Height	Total Length (L)	Total Width (W)	CC (w)
TB80-multisystem-stand	40	80	max 6000	max 6000	max 2000

Designation	No. of parallell units	A	B	D	E	M
TB80-multisystem-stand	3-10	210-500	210-250	535-1200	535-1200	160-1200