

Miniature Metal Bellows Coupling MKP

- Short design with lateral clamping hub
- High torsional stiffness - flexible

Tightening torque refers to screws.

Dimensions in mm. Length dimensions according to DIN ISO 2768 cH.

Material: Bellows: stainless steel Hubs: high-tensile strength aluminium Clamping screws: ISO 4762 - 12.9 Press-fit wire: brass

Temperature range (°C): -40° to +200°C

Max. Speed (rpm): 20 000



General Data

Designation	Nominal Torque (Nm)	Max. Torque (Nm)	Moment of inertia ($10^{-6}\text{kg}\cdot\text{m}^2$)	Torsional stiffness (Nm/arcmin)	Axial max. shaft misalignment (mm)
MKP2	2	4	2.5	400	0.3
MKP5	5	10	0.8	800	0.3
MKP7	7	14	12	1 700	0.4
MKP8	8	16	25	2 100	0.5
MKP12	12	24	28	2 600	0.4

Designation	Lateral max. shaft misalignment (mm)	Axial spring rate (N/mm)	Lateral spring rate (N/mm)	Tightening Torque (Nm)	Weight (g)
MKP2	0.1	32	100	2	30
MKP5	0.1	70	400	2	40
MKP7	0.15	70	220	4	80
MKP8	0.15	20	90	8	125
MKP12	0.15	45	190	8	130

Dimensions

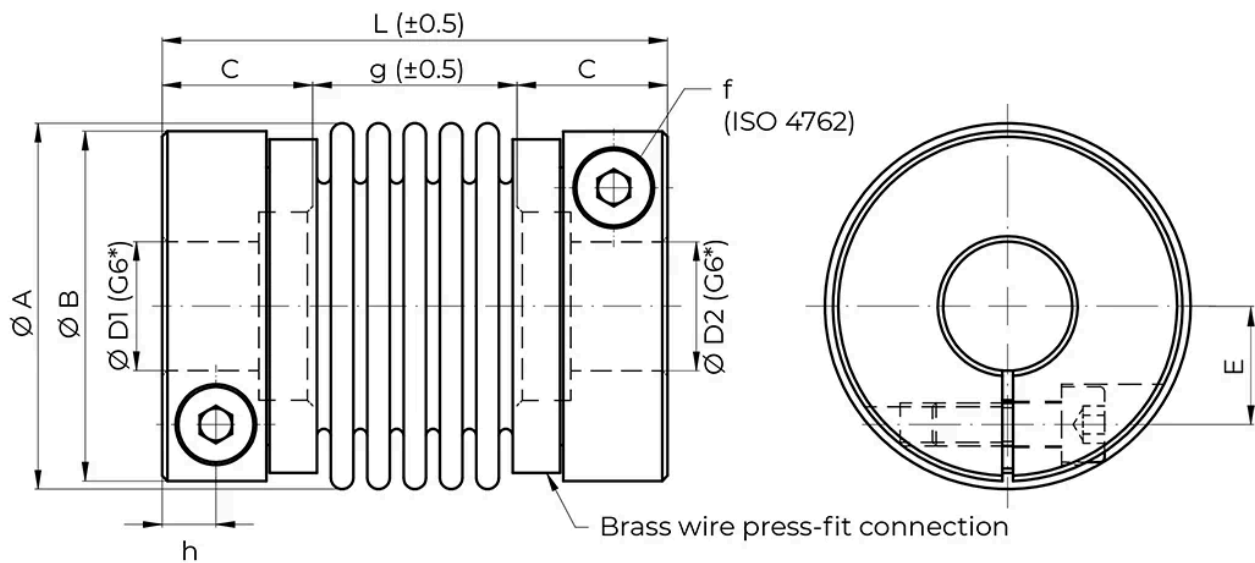

*Other bore tolerances on request.

Designation	Nominal Torque (Nm)	A	B	L	C	g	f	E	$\varnothing D1/2$ min.
MKP2	2	24.5	-	35	13	9	M3	7.5	3
MKP5	5	24.5	-	36	13	10	M3	7.5	6
MKP7	7	34 (± 0.5)	32.5	47	14	19	M4	11	6
MKP8	8	39.5	-	51	16.6	18	M5	13	6
MKP12	12	39.5	-	51	16.6	18	M5	13	6

Designation	$\varnothing D1/2$ max.
MKP2	10

Designation	ØD1/2 max.
MKP5	10
MKP7	17
MKP8	19
MKP12	19