

Elastomer Coupling ESM-A

- With conical hub on both sides
- Plug-in, backlash-free, oscillation dampening
- Rotational symmetry
- High speeds

Tightening torque refers to screws.
Peak torque is in general 1,5 times nominal.

Dimensions in mm. Length dimensions according to DIN ISO 2768 cH.

Material: Elastomer spider: polyurethane (size 2000: tempered steel) Conical hubs: high-tensile strength aluminum Clamping ring: heat treated steel - burnished
Screws: ISO 4762 - 12.9

Temperature range (°C): Depends on size, see table.



General Data

Designation	Nominal Torque (Nm)	Hardness (shore)	Moment of inertia ($10^{-9}\text{kg}\cdot\text{m}^2$)	Torsional stiffness (Nm/arcmin)	Axial max. shaft misalignment (mm)
ESM-A10	10	98 Sh-A	0.015	0.09	0.5
ESM-A17	17	98 Sh-A	0.05	0.24	0.5
ESM-A25	25	72 Sh-D	0.06	0.46	0.5
ESM-A43	43	98 Sh-A	0.19	0.7	0.5
ESM-A50	50	72 Sh-D	0.19	1.1	0.5
ESM-A60	60	98 Sh-A	0.28	1.0	0.5
ESM-A90	90	72 Sh-D	0.28	2.0	0.5
ESM-A150	150	98 Sh-A	0.65	1.2	1
ESM-A200	200	72 Sh-D	0.65	2.3	1
ESM-A320	320	98 Sh-A	2	3.6	1
ESM-A400	400	72 Sh-D	2	7.0	1
ESM-A500	500	98 Sh-A	5.6	4.5	1
ESM-A700	700	98 Sh-A	13	8	1
ESM-A1000	1 000	72 Sh-D	13	12	1
ESM-A2000	2 000	98 Sh-A	75	21	1

Designation	Lateral max. shaft misalignment (mm)	Lateral spring rate (N/mm)	Tightening Torque (Nm)	Max. Speed (rpm)	Weight (kg)	Temperature range (°C)
ESM-A10	0.1	600	2	35 000	0.11	-30° to +90°C
ESM-A17	0.1	2 100	3	28 000	0.28	-30° to +90°C
ESM-A25	0.07	2 900	3	28 000	0.28	-20° to +120°C
ESM-A43	0.1	2 500	6	23 000	0.4	-30° to +90°C
ESM-A50	0.07	3 600	6	23 000	0.4	-20° to +120°C
ESM-A60	0.1	2 600	6	21 000	0.6	-30° to +90°C
ESM-A90	0.07	3 700	6	21 000	0.6	-20° to +120°C
ESM-A150	0.1	3 300	6	18 000	0.9	-30° to +90°C
ESM-A200	0.07	4 600	6	18 000	0.9	-20° to +120°C
ESM-A320	0.12	4 500	30	14 000	1.9	-30° to +90°C
ESM-A400	0.1	6 500	30	14 000	1.9	-20° to +120°C
ESM-A500	0.15	5 900	50	11 000	4.5	-30° to +90°C
ESM-A700	0.15	7 000	100	9 500	7	-30° to +90°C
ESM-A1000	0.1	9 600	100	9 500	7	-20° to +120°C
ESM-A2000	0.15	9 000	100	7 000	20	-30° to +90°C

Dimensions

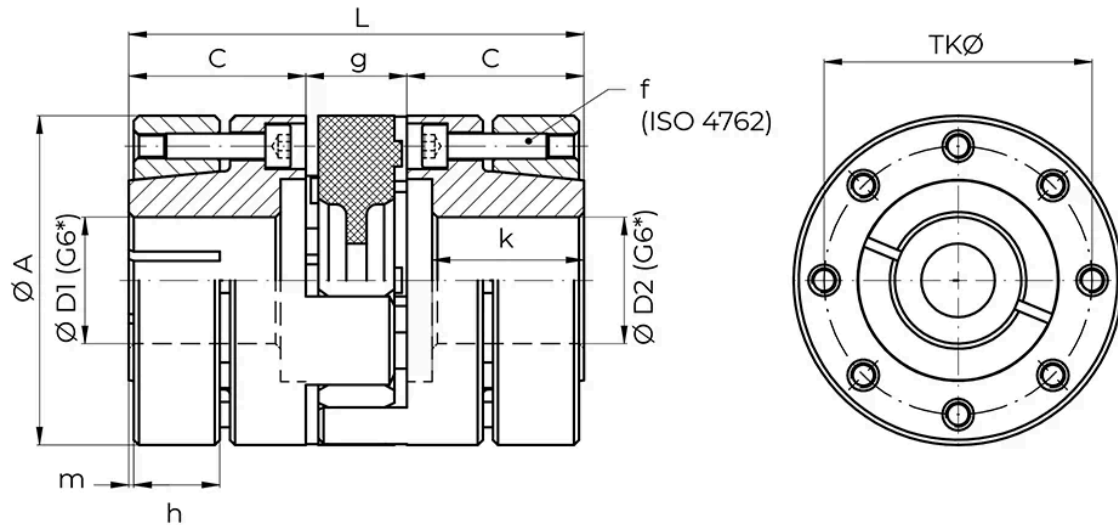

*Other bore tolerances on request.

Designation	Nominal Torque (Nm)	A	L	C	g	f	k	m	ØD1/2 min.
ESM-A10	10	32	50 (±0.5)	18.5	13	4xM3 - Ts= 2 Nm	15.5	1	6
ESM-A17	17	40	66 (±0.5)	25	16	6xM4 - Ts= 3Nm	21	1	9
ESM-A25	25	40	66 (±0.5)	25	16	6xM4 - Ts= 3Nm	21	1	10
ESM-A43	43	50	78 (±0.5)	30	18	4xM5 - Ts= 6Nm	25	1	12
ESM-A50	50	50	78 (±0.5)	30	18	4xM5 - Ts= 6Nm	25	1	15
ESM-A60	60	55	78 (±0.5)	30	18	4xM5 - Ts= 8Nm	25	1	13
ESM-A90	90	55	78 (±0.5)	30	18	4xM5 - Ts= 6Nm	25	1	17
ESM-A150	150	65	90 (±1)	35	20	8xM5 - Ts= 6Nm	30	1	17
ESM-A200	200	65	90 (±1)	35	20	8xM5 - Ts=6 Nm	30	1	19
ESM-A320	320	80	114 (±1)	45	24	4xM8 - Ts= 30Nm	40	1	20
ESM-A400	400	80	114 (±1)	45	24	4xM8 - Ts= 30Nm	40	1	25
ESM-A500	500	100	138 (±1)	55	28	4xM10 - Ts= 50Nm	48	1	22
ESM-A700	700	120	155 (±1)	61	33	4xM12 - Ts= 100Nm	54	1.2	25
ESM-A1000	1 000	120	155 (±1)	61	33	4xM12 - Ts= 100Nm	54	1	25
ESM-A2000	2 000	160	186 (±1)	73	40	8xM12 - Ts= 100Nm	73	-	35

Designation	ØD1/2 max.	ØD1/2 prebored	TKØ
ESM-A10	14	5	24.5
ESM-A17	19	9	31
ESM-A25	19	9	31
ESM-A43	24	10	39.5
ESM-A50	24	10	39.5
ESM-A60	26	12	43
ESM-A90	26	12	43
ESM-A150	36	12	53
ESM-A200	36	12	53

Designation	ØD1/2 max.	ØD1/2 prebored	TKØ
ESM-A320	40	18	64
ESM-A400	40	18	64
ESM-A500	48	20	79
ESM-A700	60	24	96
ESM-A1000	60	24	96
ESM-A2000	85	34	130