

## PSD 43 - Shaft 8 mm hollow

- Software features: spindle compensation drive, increased breakaway performance, synchronized run
- Software modules for IO-Link: changeover of parameter set, target speed in process data and modulo function
- Protection of internal electronics against manual operation
- Space-saving, compact design
- Galvanically separated supply voltages between control and motor and bus
- Precise position feedback thanks to an absolute measurement system without battery
- Optional gearbox for more torque
- Address may be set using the bus or an address switch (not for IO-Link)
- Status LEDs visible from the outside



Self-holding torque below at approx. 100 mA supply current and 1,2 A phase current, currentless 0 Nm.

Dimensions in mm.

See link Manual(s) for documentation and software.

Contact us for CAD-files.

**Type:** Vertical

**Nominal Torque (Nm):** 2

**Nominal Speed (rpm):** 200

**Nominal Voltage (V DC):** 24 (± 10 %)

**Nominal Current (A):** 4.0

**Output Shaft (mm):** 8

**Output Shaft Type:** Hollow

**Rotation Shaft / Housing:** Direct or 0°; 90°; 180°; 270°

**BUS Communication:** Can Open (CA); IO-Link (IO);

ProfiNet (PN); EtherCat (EC); Ethernet IP (EI)

**Electrical connection:** 0: Standard

**Protection Class:** IP50; IP65

**Motor:** Stepper motor

**Supply Voltage:** 24 V DC ± 10 % galvanically separated between motor and control

**Measurement System:** Absolute without battery

**Accuracy:** "±0.7 ° for versions with gearbox; ± 1.8 ° for versions without gearbox"

**Intermittence:** Start-up duration up to 30%

**Manual Adjustment:** No

**Brake:** No

Performance Curve - Direct Drives PSD



**General Data**

**PSD 432-8H (hollow shaft, 2 Nm)**

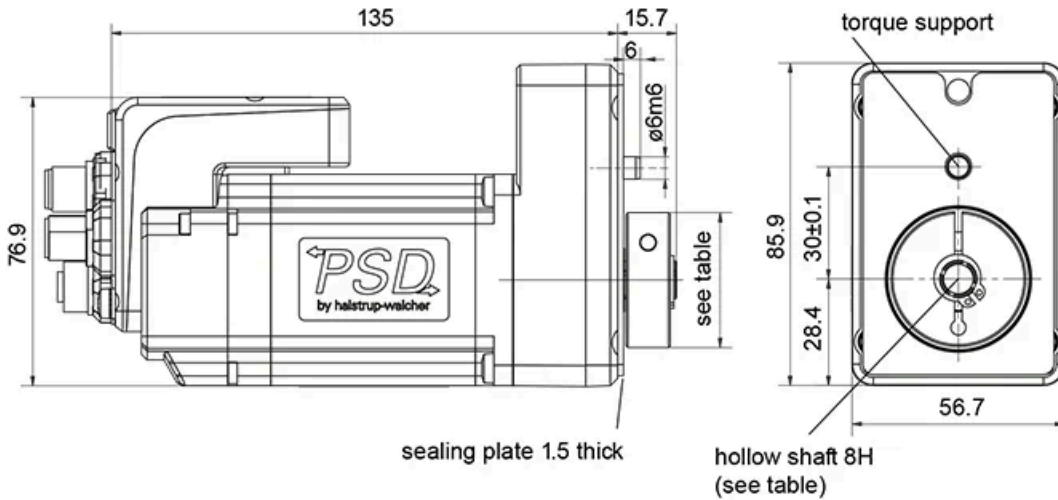

Hollow shaft	Tolerance	Plug depth	ø Clamp ring	Cylinder screw
ø8*	H9	20	36	DIN 912 M4 x 16

\* only up to 5 Nm possible

Designation	Nominal Torque (Nm)	Nominal Speed (rpm)	Nominal Current (A)	Self-holding Torque (Nm)	Max. Speed (rpm)
PSD 432-8H	2	200	4.0	1	500

Designation	Positioning Range (rot.)
PSD 432-8H	4026