

PSD 42 - Shaft 8 mm solid

- Software features: spindle compensation drive, increased breakaway performance, synchronized run
- Software modules for IO-Link: changeover of parameter set, target speed in process data and modulo function
- Protection of internal electronics against manual operation
- Space-saving, compact design
- Galvanically separated supply voltages between control and motor and bus
- Precise position feedback thanks to an absolute measurement system without battery
- Optional gearbox for more torque
- Address may be set using the bus or an address switch (not for IO-Link)
- Status LEDs visible from the outside



Self-holding torque below at approx. 100 mA supply current and 1,2 A phase current, currentless 0 Nm.

Dimensions in mm.

See link Manual(s) for documentation and software.

Type: Horizontal

Nominal Torque (Nm): 2

Nominal Speed (rpm): 200

Nominal Voltage (V DC): 24 (± 10 %)

Nominal Current (A): 4.0

Output Shaft (mm): 8

Output Shaft Type: Solid

Rotation Shaft / Housing: Direct or 0°

BUS Communication: Can Open (CA); IO-Link (IO);

ProfiNet (PN); EtherCat (EC); Ethernet IP (EI)

Electrical connection: 0: Standard

Protection Class: IP50; IP65

Motor: Stepper motor

Supply Voltage: 24 V DC ± 10 % galvanically separated between motor and control

Measurement System: Absolute without battery

Accuracy: "±0.7 ° for versions with gearbox; ± 1.8 ° for versions without gearbox"

Intermittence: Start-up duration up to 30%

Manual Adjustment: No

Brake: No

Performance Curve - Direct Drives PSD



General Data

PSD 422-8V (solid shaft)

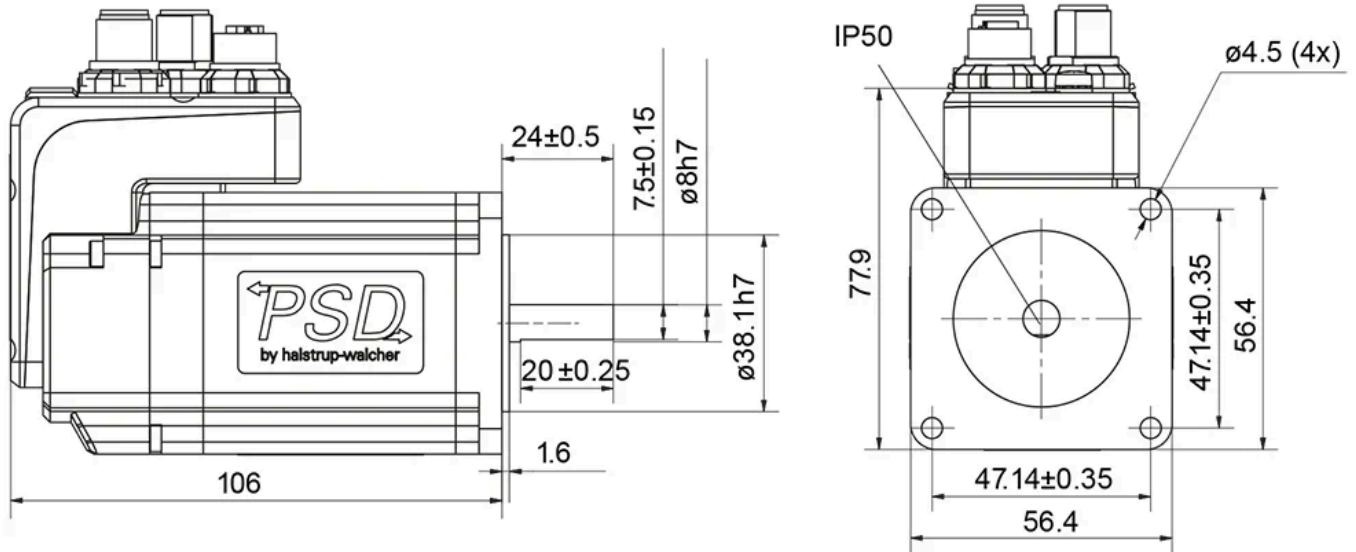

Designation	Nominal Torque (Nm)	Nominal Speed (rpm)	Nominal Current (A)	Self-holding Torque (Nm)	Max. Speed (rpm)
PSD 422-8V	2	200	4.0	1	1000

Designation	Positioning Range (rot.)
PSD 422-8V	4026