

Linear Unit MTV 40

The MTV series describes linear units with precision ball screw drive, integrated guide rail and compact dimensions. The units use a precision ball screw, with tolerance class ISO7 (ISO5 on request), with reduced backlash of the ball nut. A corrosion-resistant protection strip, protects all the parts in the profile from dust and other contaminants.

To achieve higher speeds at the same stroke of the linear unit, the ball screw support system can be integrated. With this feature vibrations and deflections of the ball screw are reduced, therefore longer strokes are possible. The linear unit with integrated support system can have a higher axial load capacity. Ball screw supports are made of high quality plastic materials with high wear resistance properties. The system enables ball screw support in horizontal or vertical positioning of the linear unit.

A 2LR version of MTV linear unit is available, where two carriages are moving simultaneously in opposite directions. Both right- and left-handed precision ball screws are used, which are rigidly connected. The ball screw support system can also be integrated.

Dimensions in mm.

Modulus of Elasticity: $E = 70000 \text{ N / mm}^2$

Operating Temperature (°C): 0 ~ +60 For operating temperature out of the presented range, please contact Rollco.

Duty Cycle: 100%

Max. Acceleration (m/s²): 20



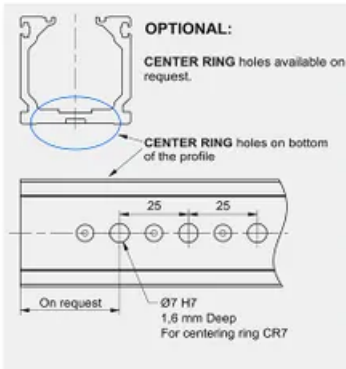

Mounting the drive

- by the MOTOR SIDE DRIVE - MSD
- by the MOTOR ADAPTER WITH COUPLING

Defining of the linear unit length

Standard version

$L = \text{Effective stroke} + 2 \times \text{Safety stroke} = L_v + 2 \times L_{sa} = A \times (n_c - 1) + 10 \text{ mm}$
 $L_{total} = L + 45 \text{ mm}$, $L_v = 150 \text{ mm}$
 Left side (L)

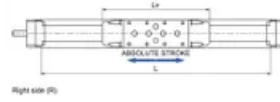

Multiple carriages

n_c - Number of carriages
 $A \times L_v$ - Distances between the carriages must be provided by the customer



Maximum travel speed as a function of the profile length (vmax - L curves)

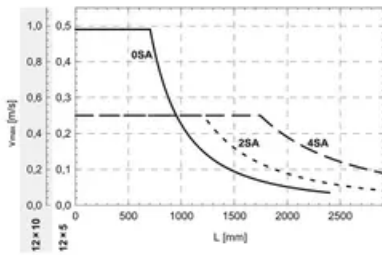

General Data

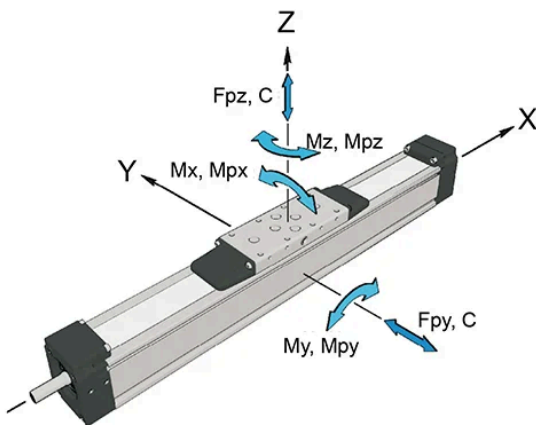

For lengths/stroke over the stated value please contact us. Values for max. stroke are not valid for multiple carriages and screw support SA (equation of defining the linear unit length for particular size of the linear unit need to be used).

Recommended values of loads

All the data of dynamic moments and load capacities are theoretical without considering any safety factor. The safety factor depends on the application and its requested safety. We recommend a minimum safety factor ($f_s = 5.0$).

Designation	Carriage Length L_v (mm)	Dynamic Load Capacity C (N)	Dynamic Moment M_x (Nm)	Dynamic Moment M_y (Nm)	Dynamic Moment M_z (Nm)
MTV 40 - 12 x 5	150	4620	28	260	260
MTV 40 - 12 x 10	150	4620	28	260	260

Designation	Max. Permissible Loads Forces Fpy (N)	Max. Permissible Loads Forces Fpz (N)	Max. Permissible Loads Moments Mpy (Nm)	Max. Permissible Loads Moments Mpz (Nm)	Max. Length Lmax (mm)	Max. Stroke (mm)
MTV 40 - 12 x 5	2300	3850	210	130	2900	2728
MTV 40 - 12 x 10	2300	3850	210	130	2900	2728

Designation	Min. Stroke (mm)
MTV 40 - 12 x 5	30
MTV 40 - 12 x 10	30

Drive Data

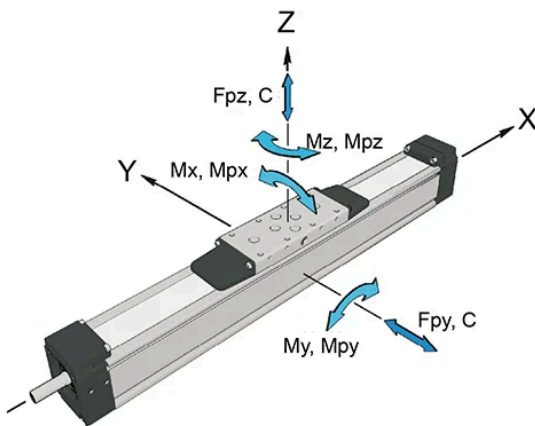

- Max. travel speed depends of the length of the linear unit, see diagram for particular size of the linear unit. For travel speed and acceleration over the stated value, please contact Rollco.
- For the ball nut with the preload of 2%, please contact Rollco.
- For minimum stroke below the stated value, please contact Rollco.

Designation	Max. Rotational Speed (without SA) (rev/min)	Max. Travel Speed (without SA) (m/s)	Lead Constant (mm/rev)	Ball Screw (d x l)	Max. Repeatability Precision Standard ISO7
MTV 40 - 12 x 5	5800	0.49	5	12 x 5	±0.02
MTV 40 - 12 x 10	5800	0.97	10	12 x 10	±0.02

Designation	Max. Repeatability Precision ISO5	Dynamic Load Capacity BS Ca (N)	Max. Axial Load Fx (N)	Max. Drive Torque Ma (Nm)	Planar Moment of Inertia Iy (cm ⁴)	Planar Moment of Inertia Iz (cm ⁴)
MTV 40 - 12 x 5	±0.01	5000	3400	3	10	11
MTV 40 - 12 x 10	±0.01	3800	2540	4.5	10	11

Designation	Max. Acceleration (m/s)
MTV 40 - 12 x 5	20
MTV 40 - 12 x 10	20

Mass and Mass Moment

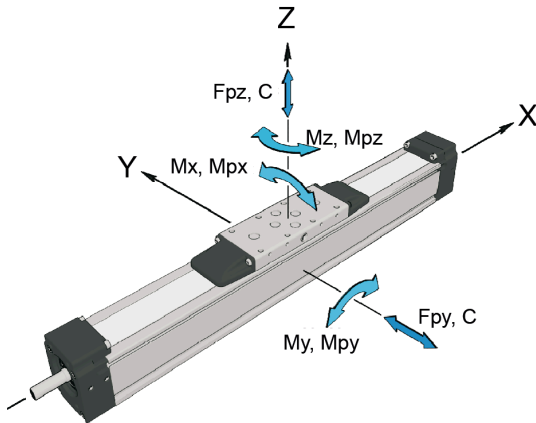

The stated values are for strokes (and for distances between carriages up to 500 mm.

No load torque value increases with stroke (and with A) elongation.

Mass calculation does not include mass of motor, reduction gear, switches and clamps.

Abs. stroke	Absolute stroke [mm]
A	Distance between carriages [mm]
nc	Number of carriages

Designation	Ball Screw (d x l)	Number of SA "SA	Mass of Linear Unit (kg)	Moved Mass (kg)	Mass Moment of Inertia (10 ⁻⁵ kg m ²)
MTV 40 - 12 x 5	12 x 5	0 ; 2 ; 4	$1.2 + 0.0028 \times (\text{Abs. Stroke} + (\text{nc} - 1) \times A) + 0.47 \times (\text{nc} - 1) ; 1.3 + 0.0028 \times (\text{Abs. Stroke} + (\text{nc} - 1) \times A) + 0.47 \times (\text{nc} - 1) ; 1.4 + 0.0028 \times (\text{Abs. Stroke} + (\text{nc} - 1) \times A) + 0.47 \times (\text{nc} - 1)$	$0.47 + 0.47 \times (\text{nc} - 1) ; 0.50 + 0.47 \times (\text{nc} - 1) ; 0.53 + 0.47 \times (\text{nc} - 1)$	$0.48 + 0.0012 \times (\text{Abs. Stroke} + (\text{nc} - 1) \times A) + 0.03 \times (\text{nc} - 1) ; 0.53 + 0.0012 \times (\text{Abs. Stroke} + (\text{nc} - 1) \times A) + 0.03 \times (\text{nc} - 1) ; 0.57 + 0.0012 \times (\text{Abs. Stroke} + (\text{nc} - 1) \times A) + 0.03 \times (\text{nc} - 1)$
MTV 40 - 12 x 10	12 x 10	0 ; 2 ; 4	$1.2 + 0.0028 \times (\text{Abs. Stroke} + (\text{nc} - 1) \times A) + 0.47 \times (\text{nc} - 1) ; 1.3 + 0.0028 \times (\text{Abs. Stroke} + (\text{nc} - 1) \times A) + 0.47 \times (\text{nc} - 1) ; 1.4 + 0.0028 \times (\text{Abs. Stroke} + (\text{nc} - 1) \times A) + 0.47 \times (\text{nc} - 1)$	$0.47 + 0.47 \times (\text{nc} - 1) ; 0.50 + 0.47 \times (\text{nc} - 1) ; 0.53 + 0.47 \times (\text{nc} - 1)$	$0.57 + 0.0012 \times (\text{Abs. Stroke} + (\text{nc} - 1) \times A) + 0.12 \times (\text{nc} - 1) ; 0.62 + 0.0012 \times (\text{Abs. Stroke} + (\text{nc} - 1) \times A) + 0.12 \times (\text{nc} - 1) ; 0.67 + 0.0012 \times (\text{Abs. Stroke} + (\text{nc} - 1) \times A) + 0.12 \times (\text{nc} - 1)$

Designation	No Load Torque (Nm)	Planar Moment of Inertia ly (cm ⁴)	Planar Moment of Inertia lz (cm ⁴)
MTV 40 - 12 x 5	$0.08 + 0.08 \times (\text{nc} - 1) ; 0.09 + 0.08 \times (\text{nc} - 1) ; 0.10 + 0.08 \times (\text{nc} - 1)$	10	11
MTV 40 - 12 x 10	$0.09 + 0.09 \times (\text{nc} - 1) ; 0.11 + 0.09 \times (\text{nc} - 1) ; 0.14 + 0.09 \times (\text{nc} - 1)$	10	11