

## Linear Unit MTV 80

The MTV series describes linear units with precision ball screw drive, integrated guide rail and compact dimensions. The units use a precision ball screw, with tolerance class ISO7 (ISO5 on request), with reduced backlash of the ball nut. A corrosion-resistant protection strip, protects all the parts in the profile from dust and other contaminants.

To achieve higher speeds at the same stroke of the linear unit, the ball screw support system can be integrated. With this feature vibrations and deflections of the ball screw are reduced, therefore longer strokes are possible. The linear unit with integrated support system can have a higher axial load capacity. Ball screw supports are made of high quality plastic materials with high wear resistance properties. The system enables ball screw support in horizontal or vertical positioning of the linear unit.

A 2LR version of MTV linear unit is available, where two carriages are moving simultaneously in opposite directions. Both right- and left-handed precision ball screws are used, which are rigidly connected. The ball screw support system can also be integrated.

Dimensions in mm.

**Modulus of Elasticity:**  $E = 70000 \text{ N / mm}^2$

**Operating Temperature (°C):** 0 ~ +60 For operating temperature out of the presented range, please contact Rollco.

**Duty Cycle:** 100%

**Max. Acceleration (m/s<sup>2</sup>):** 20





1. Drive block with floating bearing (MTV 110 - fixed bearing)
2. Corrosion-resistant protection strip
3. Ball screw tolerance ISO7 (ISO5 available on request)
4. Carriage with built in magnets
5. Aluminium profile - hard anodized
6. Screw support - SA
7. Integrated linear ball guideway
8. Central lubrication port, both sides
9. End block with fixed bearing (MTV 110 - floating bearing)



1. Right hand ball screw
2. Carriage with built in right hand ball nut
3. Carriage with built in left hand ball nut
4. Screw support - SA
5. Central screw support - fixed
6. Left hand ball screw

### Deflection of the linear unit (standard)

Fixed - fixed mounting

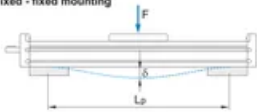

- $\delta$  Maximum deflection of the linear unit [mm]
- $\delta_{max}$  Maximum permissible deflection of the linear unit [mm]
- F Applied force [N]
- $L_p$  Unsupported profile length [mm]

Fixed - free mounting

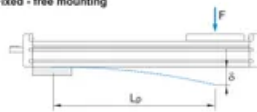

The maximum permissible deflection  $\delta_{max}$  must not be exceeded. In the case that maximum deflection  $\delta$  exceeds the maximum permissible deflection  $\delta_{max}$  additional profile supports are needed.

### Deflection of the 2LR version

Fixed - fixed mounting

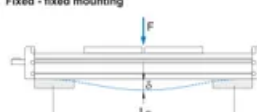

- $\delta$  Maximum deflection of the linear unit [mm]
- $\delta_{max}$  Maximum permissible deflection of the linear unit [mm]
- F Applied force [N]
- $L_p$  Unsupported profile length [mm]

The maximum permissible deflection  $\delta_{max}$  must not be exceeded. In the case that maximum deflection  $\delta$  exceeds the maximum permissible deflection  $\delta_{max}$  additional profile supports are needed.

### Deflection of the linear unit

MTV 80

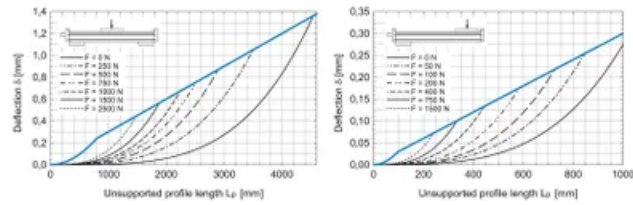

### Deflection of the 2LR version

MTV 80

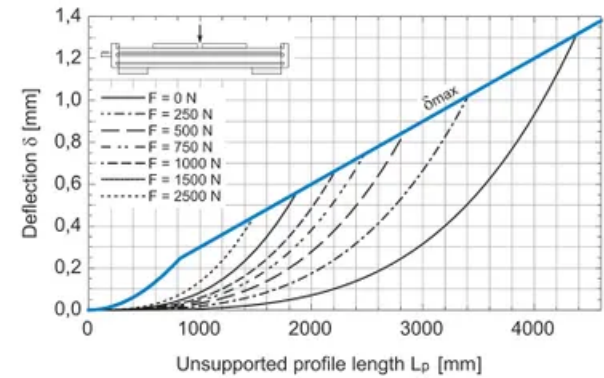

① The linear units do not include any safety stroke.  
Absolute stroke = Effective stroke + 2 x safety stroke

| n   | L <sub>tot</sub> | n    | L <sub>tot</sub> |
|-----|------------------|------|------------------|
| 2   | 8.2              | 45A  | 96.8             |
| 25A | 30.5             | 55A  | 121.5            |
| 40A | 58.8             | 105A | 152.5            |

L<sub>tot</sub> Axle length [mm]



① Journal with or without keyway ② All dimensions in mm. Drawings scales are not equal!

① The linear units do not include any safety stroke.  
Absolute stroke = Effective stroke + 2 x safety stroke

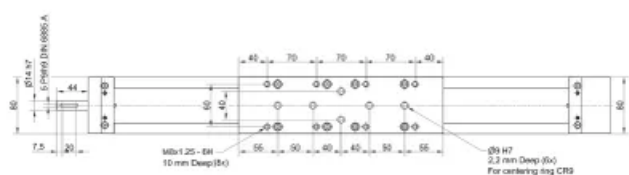

① Journal with or without keyway ② All dimensions in mm. Drawings scales are not equal!

① The linear units do not include any safety stroke  
 Absolute stroke = Effective stroke + 2 x safety stroke

|      | L <sub>SA</sub> | L <sub>EA</sub> |
|------|-----------------|-----------------|
| 0    | 0,0             | 0,0             |
| 2SA  | 28,9            | 48,0            |
| 4SA  | 56,8            | 112,0           |
| 6SA  | 84,7            | 172,0           |
| 8SA  | 112,6           | 234,0           |
| 10SA | 140,5           | 298,0           |

L<sub>SA</sub> Additional length (mm)  
 L<sub>EA</sub> Max. distance between carriages (mm)

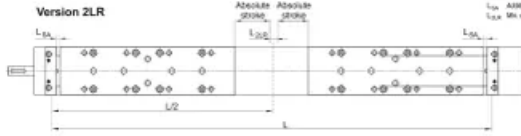

① Journal with or without keyway    ② All dimensions in mm. Drawings scales are not equal!

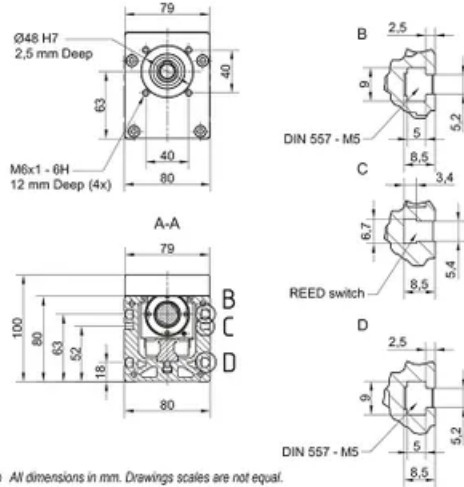

① All dimensions in mm. Drawings scales are not equal.

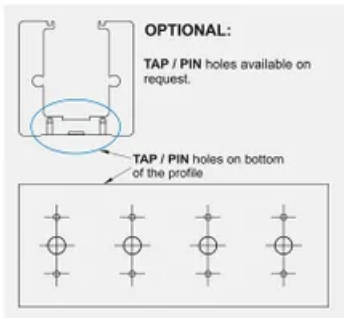

### Mounting the drive

- by the MOTOR SIDE DRIVE - MSD
- by the MOTOR ADAPTER WITH COUPLING

### Defining of the linear unit length

#### Standard version

$$L = \text{Effective stroke} + 2 \times \text{Safety stroke} + L_v + 2 \times L_{SA} + 10 \text{ mm}$$

$$L_{total} = L + 81 \text{ mm}$$

$$L_v = 290 \text{ mm}$$

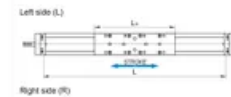

#### Version ZLR

$$L = 2 \times (\text{Effective stroke} + 2 \times \text{Safety stroke}) + 2 \times L_v + 2 \times L_{SA} + 10 \text{ mm}$$

$$L_{total} = L + 81 \text{ mm}$$

$$L_v = 290 \text{ mm}$$

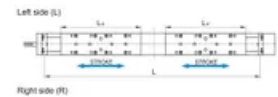

### Maximum travel speed as a function of the profile length (vmax - L curves)

#### Standard version

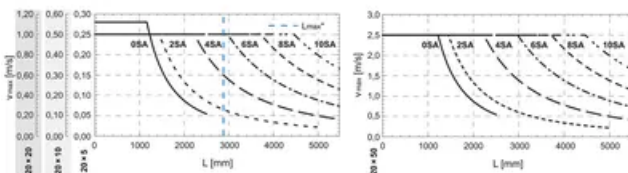

\* Maximum length L<sub>max</sub> of MTV 80 linear unit with 20x10 ball screw

### Maximum travel speed as a function of the profile length (vmax - L curves)

#### ZLR version

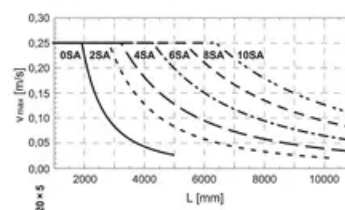

### Exceptions for standard version

| Linear Unit | Number of SA<br>nSA | Max length<br>Lmax (mm) | Max stroke<br>(mm) |
|-------------|---------------------|-------------------------|--------------------|
| MTV80       | 0                   | 2500                    | 2183               |
|             | 2                   | 5010                    | 4648               |

Stated values in the table apply only for horizontally orientated unit.

| Linear Unit | Ball screw<br>(d x l) | Max length<br>Lmax (mm) | Max stroke<br>(mm) |
|-------------|-----------------------|-------------------------|--------------------|
| MTV 80      | 20 X 10               | 2880                    | 2563               |

Exceptions for maximum length and stroke!

### Exceptions for 2LR version

| Linear Unit | Number of SA<br>nSA | Max length<br>Lmax (mm) | Max stroke<br>(mm) |
|-------------|---------------------|-------------------------|--------------------|
| MTV80 2LR   | 0                   | 4973                    | 2183               |
|             | 2                   | 10200                   | 4750               |

Exceptions for maximum length and stroke!

## General Data

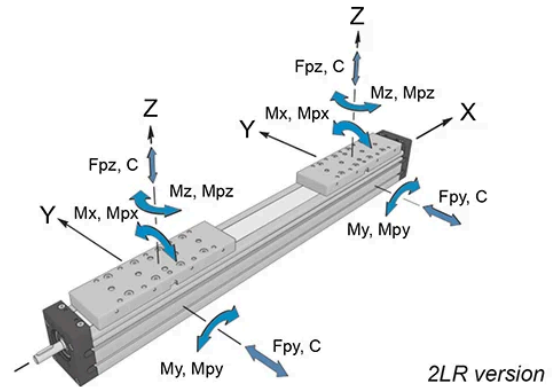
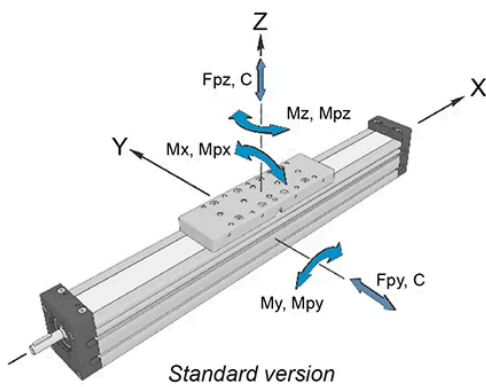

For lengths/stroke over the stated value please contact us. Values for max. stroke are not valid for screw support SA. For the case of the SA the equation of defining the linear unit length (for particular size of the linear units) needs to be used.

### Recommended values of loads

All the data of static and dynamic moments and load capacities are theoretical without considering any safety factor. The safety factor depends on the application and its requested safety. We recommend a minimum safety factor ( $f_s = 5.0$ ).

| Designation         | Carriage Length<br>Lv (mm) | Dynamic Load<br>Capacity C (N) | Static Load<br>Capacity C0 (N) | Dynamic Moment<br>Mx (Nm) | Dynamic Moment<br>My (Nm) |
|---------------------|----------------------------|--------------------------------|--------------------------------|---------------------------|---------------------------|
| MTV 80 - 20 x 5     | 290                        | 34200                          | 60000                          | 370                       | 1470                      |
| MTV 80 2LR - 20 x 5 | 290                        | 34200                          | 60000                          | 370                       | 1470                      |
| MTV 80 - 20 x 10    | 290                        | 34200                          | 60000                          | 370                       | 1470                      |
| MTV 80 - 20 x 20    | 290                        | 34200                          | 60000                          | 370                       | 1470                      |
| MTV 80 - 20 x 50    | 290                        | 34200                          | 60000                          | 370                       | 1470                      |

| Designation         | Dynamic<br>Moment Mz<br>(Nm) | Max. Permissible<br>Loads Forces Fpy<br>(N) | Max. Permissible<br>Loads Forces Fpz<br>(N) | Max. Permissible<br>Loads Moments<br>Mpy (Nm) | Max. Permissible<br>Loads Moments<br>Mpz (Nm) | Max.<br>Length<br>Lmax<br>(mm) |
|---------------------|------------------------------|---|---|---|---|--------------------------------|
| MTV 80 - 20 x 5     | 1470                         | 8930  | 15070                                       | 500   | 384   | 5480                           |
| MTV 80 2LR - 20 x 5 | 1470                         | 8930  | 15070                                       | 500   | 384   | 11055                          |
| MTV 80 - 20 x 10    | 1470                         | 8930  | 15070                                       | 500   | 384   | 5480                           |

| Designation      | Dynamic Moment Mz (Nm) | Max. Permissible Loads Forces Fpy (N) | Max. Permissible Loads Forces Fpz (N) | Max. Permissible Loads Moments Mpy (Nm) | Max. Permissible Loads Moments Mpz (Nm) | Max. Length Lmax (mm) |
|------------------|------------------------|---------------------------------------|---------------------------------------|---|---|-----------------------|
| MTV 80 - 20 x 20 | 1470                   | 8930                                  | 15070                                 | 500                                     | 384                                     | 5480                  |
| MTV 80 - 20 x 50 | 1470                   | 8930                                  | 15070                                 | 500                                     | 384                                     | 5480                  |

| Designation         | Max. Stroke (mm) | Min. Stroke (mm) |
|---------------------|------------------|------------------|
| MTV 80 - 20 x 5     | 5163             | 55               |
| MTV 80 2LR - 20 x 5 | 5224             | 55               |
| MTV 80 - 20 x 10    | 5163             | 55               |
| MTV 80 - 20 x 20    | 5163             | 55               |
| MTV 80 - 20 x 50    | 5163             | 55               |

## Drive Data

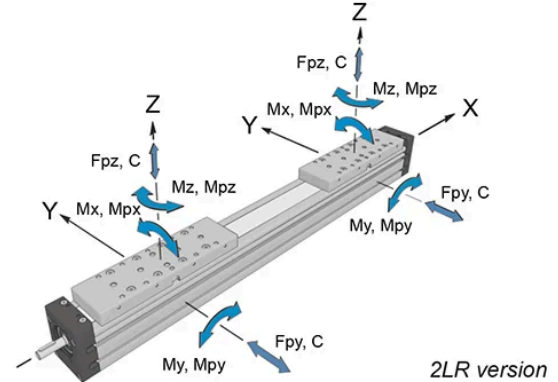
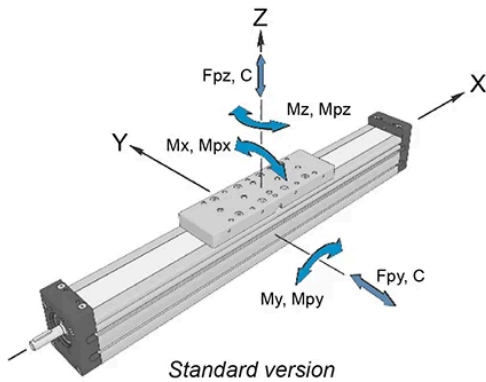

- With SA or 2LR version the max. rotation speed is limited to 3000 rev/min.
- Max. travel speed depends of the length of the linear unit, see diagram for particular size of the linear unit. For travel speed over the stated value, please contact Rollco.
- For the ball nut with the preload of 2%, please contact Rollco.
- In the case of 2RL version the axial load is total axial load of both carriages.
- For minimum stroke below the stated value, please contact Rollco.

Max. acceleration (m/s<sup>2</sup>): 20\*

For acceleration over the stated value, please contact Rollco.

Reduced effective diameter at journal with keyway decreases values of max. drive torque.

| Designation         | Max. Rotational Speed (without SA) (rev/min) | Max. Travel Speed (without SA) (m/s) | Lead Constant (mm/rev) | Ball Screw (d x l) | Max. Repeatability Precision Standard ISO7 |
|---------------------|--|--------------------------------------|------------------------|--------------------|--|
| MTV 80 - 20 x 5     | 3300   | 0.28                                 | 5                      | 20 x 5             | ±0.02                                      |
| MTV 80 2LR - 20 x 5 | 3300   | 0.28                                 | 5                      | 20 x 5             | ±0.02                                      |
| MTV 80 - 20 x 10    | 3300   | 0.55                                 | 10                     | 20 x 10            | ±0.02                                      |
| MTV 80 - 20 x 20    | 3300   | 1.10                                 | 20                     | 20 x 20            | ±0.02                                      |
| MTV 80 - 20 x 50    | 3000   | 2.50                                 | 50                     | 20 x 50            | ±0.02                                      |

| Designation     | Max. Repeatability Precision ISO5 | Dynamic Load Capacity BS Ca (N) | Max. Axial Load Fx (N) | Max. Drive Torque Ma (Nm)            | Planar Moment of Inertia Iy (cm <sup>4</sup> ) | Planar Moment of Inertia Iz (cm <sup>4</sup> ) |
|-----------------|-----------------------------------|---------------------------------|------------------------|--------------------------------------|--|--|
| MTV 80 - 20 x 5 | ±0.01                             | 14800                           | 14800                  | 11.9 with keyway / 13 without keyway | 144.1  | 192.3  |

| Designation         | Max. Repeatability Precision ISO5 | Dynamic Load Capacity BS Ca (N) | Max. Axial Load Fx (N) | Max. Drive Torque Ma (Nm)              | Planar Moment of Inertia Iy (cm <sup>4</sup> ) | Planar Moment of Inertia Iz (cm <sup>4</sup> ) |
|---------------------|-----------------------------------|---------------------------------|------------------------|--|--|--|
| MTV 80 2LR - 20 x 5 | ±0.01                             | 14800                           | 14800                  | 11.9 with keyway / 13 without keyway   | 144.1  | 192.3  |
| MTV 80 - 20 x 10    | ±0.01                             | 15900                           | 13850                  | 11.9 with keyway / 24.5 without keyway | 144.1  | 192.3  |
| MTV 80 - 20 x 20    | ±0.01                             | 16250                           | 6930                   | 11.9 with keyway / 24.5 without keyway | 144.1  | 192.3  |
| MTV 80 - 20 x 50    | ±0.01                             | 13000                           | 2770                   | 11.9 with keyway / 24.5 without keyway | 144.1  | 192.3  |

## Mass and Mass Moment

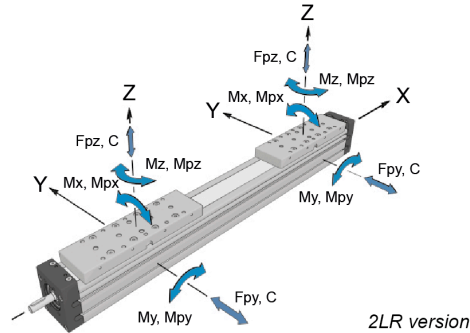
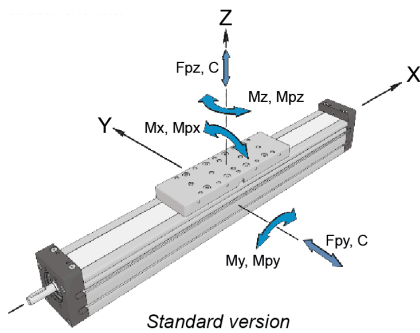

The stated values are for strokes up to 500 mm. No load torque value increases with stroke elongation.

Mass calculation does not include mass of motor, reduction gear, switches and clamps.

|             |                                 |
|-------------|---------------------------------|
| Abs. stroke | Absolute stroke [mm]            |
| A           | Distance between carriages [mm] |
| nc          | Number of carriages             |

| Designation         | Ball Screw (d x l) | Number of SA nSA         | Mass of Linear Unit (kg)  | Moved Mass (kg)  | Mass Moment of Inertia (10 <sup>-5</sup> kg m <sup>2</sup> )  |
|---------------------|--------------------|--------------------------|---|--|---|
| MTV 80 - 20 x 5     | 20 x 5             | 0 ; 2 ; (4 ; 6 ; 8 ; 10) | $8.2 + 0.0114 \times (\text{Abs. Stroke} + (\text{nc} - 1) \times A) + 3.0 \times (\text{nc} - 1) ; 8.9 + 0.0114 \times (\text{Abs. Stroke} + (\text{nc} - 1) \times A) + 3.0 \times (\text{nc} - 1) ; 9.7 + 0.4 \times (\text{nSA} - 4) + 0.0114 \times (\text{Abs. Stroke} + (\text{nc} - 1) \times A) + 3.0 \times (\text{nc} - 1)$    | $3.00 + 3.00 \times (\text{nc} - 1) ; 3.07 + 3.00 \times (\text{nc} - 1) ; 3.21 + 0.035 \times (\text{nSA} - 4) + 3.00 \times (\text{nc} - 1)$ | $5.6 + 0.0127 \times (\text{Abs. Stroke} + (\text{nc} - 1) \times A) + 0.19 \times (\text{nc} - 1) ; 6.2 + 0.0127 \times (\text{Abs. Stroke} + (\text{nc} - 1) \times A) + 0.19 \times (\text{nc} - 1) ; 7.0 + 0.4 \times (\text{nSA} - 4) + 0.0127 \times (\text{Abs. Stroke} + (\text{nc} - 1) \times A) + 0.19 \times (\text{nc} - 1)$   |
| MTV 80 2LR - 20 x 5 | 20 x 5             | 0 ; 2 ; (4 ; 6 ; 8 ; 10) | $14.6 + 0.0228 \times (\text{Abs. Stroke} + (\text{nc} - 1) \times A) + 6.0 \times (\text{nc} - 1) ; 15.9 + 0.0228 \times (\text{Abs. Stroke} + (\text{nc} - 1) \times A) + 6.0 \times (\text{nc} - 1) ; 17.6 + 0.8 \times (\text{nSA} - 4) + 0.0228 \times (\text{Abs. Stroke} + (\text{nc} - 1) \times A) + 6.0 \times (\text{nc} - 1)$ | $6.00 + 6.00 \times (\text{nc} - 1) ; 6.14 + 6.00 \times (\text{nc} - 1) ; 6.42 + 0.07 \times (\text{nSA} - 4) + 6.00 \times (\text{nc} - 1)$  | $9.5 + 0.0254 \times (\text{Abs. Stroke} + (\text{nc} - 1) \times A) + 0.38 \times (\text{nc} - 1) ; 10.7 + 0.0254 \times (\text{Abs. Stroke} + (\text{nc} - 1) \times A) + 0.38 \times (\text{nc} - 1) ; 12.3 + 0.8 \times (\text{nSA} - 4) + 0.0254 \times (\text{Abs. Stroke} + (\text{nc} - 1) \times A) + 0.38 \times (\text{nc} - 1)$ |
| MTV 80 - 20 x 10    | 20 x 10            | 0 ; 2 ; (4 ; 6 ; 8 ; 10) | $8.2 + 0.0114 \times (\text{Abs. Stroke} + (\text{nc} - 1) \times A) + 3.0 \times (\text{nc} - 1) ; 8.9 + 0.0114 \times (\text{Abs. Stroke} + (\text{nc} - 1) \times A) + 3.0 \times (\text{nc} - 1) ; 9.7 + 0.4 \times (\text{nSA} - 4) + 0.0114 \times (\text{Abs. Stroke} + (\text{nc} - 1) \times A) + 3.0 \times (\text{nc} - 1)$    | $3.00 + 3.00 \times (\text{nc} - 1) ; 3.07 + 3.00 \times (\text{nc} - 1) ; 3.21 + 0.035 \times (\text{nSA} - 4) + 3.00 \times (\text{nc} - 1)$ | $6.2 + 0.0127 \times (\text{Abs. Stroke} + (\text{nc} - 1) \times A) + 0.76 \times (\text{nc} - 1) ; 6.8 + 0.0127 \times (\text{Abs. Stroke} + (\text{nc} - 1) \times A) + 0.76 \times (\text{nc} - 1) ; 7.6 + 0.4 \times (\text{nSA} - 4) + 0.0127 \times (\text{Abs. Stroke} + (\text{nc} - 1) \times A) + 0.76 \times (\text{nc} - 1)$   |

| Designation      | Ball Screw (d x l) | Number of SA nSA         | Mass of Linear Unit (kg)   | Moved Mass (kg)  | Mass Moment of Inertia (10 <sup>-5</sup> kg m <sup>2</sup> )  |
|------------------|--------------------|--------------------------|--|--|---|
| MTV 80 - 20 x 20 | 20 x 20            | 0 ; 2 ; (4 ; 6 ; 8 ; 10) | $8.2 + 0.0114 \times (\text{Abs. Stroke} + (\text{nc} - 1) \times A) + 3.0 \times (\text{nc} - 1) ; 8.9 + 0.0114 \times (\text{Abs. Stroke} + (\text{nc} - 1) \times A) + 3.0 \times (\text{nc} - 1) ; 9.7 + 0.4 \times (\text{nSA} - 4) + 0.0114 \times (\text{Abs. Stroke} + (\text{nc} - 1) \times A) + 3.0 \times (\text{nc} - 1)$ | $3.00 + 3.00 \times (\text{nc} - 1) ; 3.07 + 3.00 \times (\text{nc} - 1) ; 3.21 + 0.035 \times (\text{nSA} - 4) + 3.00 \times (\text{nc} - 1)$ | $8.5 + 0.0127 \times (\text{Abs. Stroke} + (\text{nc} - 1) \times A) + 3.04 \times (\text{nc} - 1) ; 9.1 + 0.0127 \times (\text{Abs. Stroke} + (\text{nc} - 1) \times A) + 3.04 \times (\text{nc} - 1) ; 10.1 + 0.5 \times (\text{nSA} - 4) + 0.0127 \times (\text{Abs. Stroke} + (\text{nc} - 1) \times A) + 3.04 \times (\text{nc} - 1)$      |
| MTV 80 - 20 x 50 | 20 x 50            | 0 ; 2 ; (4 ; 6 ; 8 ; 10) | $8.2 + 0.0114 \times (\text{Abs. Stroke} + (\text{nc} - 1) \times A) + 3.0 \times (\text{nc} - 1) ; 8.9 + 0.0114 \times (\text{Abs. Stroke} + (\text{nc} - 1) \times A) + 3.0 \times (\text{nc} - 1) ; 9.7 + 0.4 \times (\text{nSA} - 4) + 0.0114 \times (\text{Abs. Stroke} + (\text{nc} - 1) \times A) + 3.0 \times (\text{nc} - 1)$ | $3.00 + 3.00 \times (\text{nc} - 1) ; 3.07 + 3.00 \times (\text{nc} - 1) ; 3.21 + 0.035 \times (\text{nSA} - 4) + 3.00 \times (\text{nc} - 1)$ | $24.4 + 0.0127 \times (\text{Abs. Stroke} + (\text{nc} - 1) \times A) + 19.00 \times (\text{nc} - 1) ; 25.5 + 0.0127 \times (\text{Abs. Stroke} + (\text{nc} - 1) \times A) + 19.00 \times (\text{nc} - 1) ; 27.1 + 0.6 \times (\text{nSA} - 4) + 0.0127 \times (\text{Abs. Stroke} + (\text{nc} - 1) \times A) + 19.00 \times (\text{nc} - 1)$ |

| Designation         | No Load Torque (Nm)  | Planar Moment of Inertia Iy (cm <sup>4</sup> ) | Planar Moment of Inertia Iz (cm <sup>4</sup> ) |
|---------------------|--|--|--|
| MTV 80 - 20 x 5     | $0.23 + 0.23 \times (\text{nc} - 1) ; 0.26 + 0.23 \times (\text{nc} - 1) ; 0.31 + 0.015 \times (\text{nSA} - 4) + 0.23 \times (\text{nc} - 1)$ | 144.1  | 192.3  |
| MTV 80 2LR - 20 x 5 | $0.46 + 0.46 \times (\text{nc} - 1) ; 0.51 + 0.46 \times (\text{nc} - 1) ; 0.62 + 0.03 \times (\text{nSA} - 4) + 0.46 \times (\text{nc} - 1)$  | 144.1  | 192.3  |
| MTV 80 - 20 x 10    | $0.25 + 0.25 \times (\text{nc} - 1) ; 0.30 + 0.25 \times (\text{nc} - 1) ; 0.41 + 0.025 \times (\text{nSA} - 4) + 0.25 \times (\text{nc} - 1)$ | 144.1  | 192.3  |
| MTV 80 - 20 x 20    | $0.30 + 0.30 \times (\text{nc} - 1) ; 0.41 + 0.30 \times (\text{nc} - 1) ; 0.62 + 0.055 \times (\text{nSA} - 4) + 0.30 \times (\text{nc} - 1)$ | 144.1  | 192.3  |
| MTV 80 - 20 x 50    | $0.70 + 0.70 \times (\text{nc} - 1) ; 0.97 + 0.70 \times (\text{nc} - 1) ; 1.50 + 0.135 \times (\text{nSA} - 4) + 0.70 \times (\text{nc} - 1)$ | 144.1  | 192.3  |