

CCT

Sliders with four rollers, arranged in pairs, maintain the preload over the entire rail length. Pivoting roller mounts coupled with concentric and eccentric rollers allows for a smooth operation over complex rail layouts.

Slider in stainless steel is available as an option, contact Rollco for more information.

We customize each application according to drawing.

See document Technical Information for further details.

Dimensions in mm.

Please contact us for CAD-files.



General Data

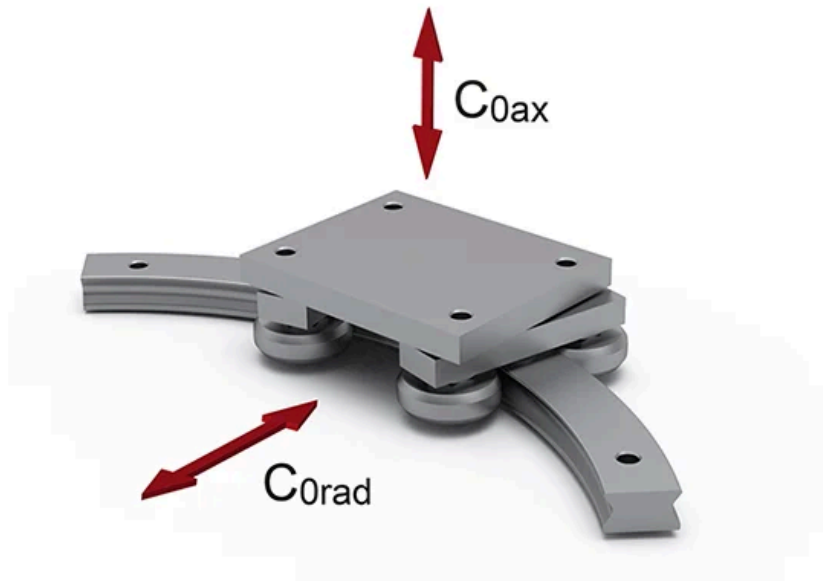

Designation	Weight (kg)	Load Capacity C_{0ax} (N)	Load Capacity C_{0rad} (N)
CCT08	0.45	400	570
CCT11	1.10	1130	1615

Dimensions

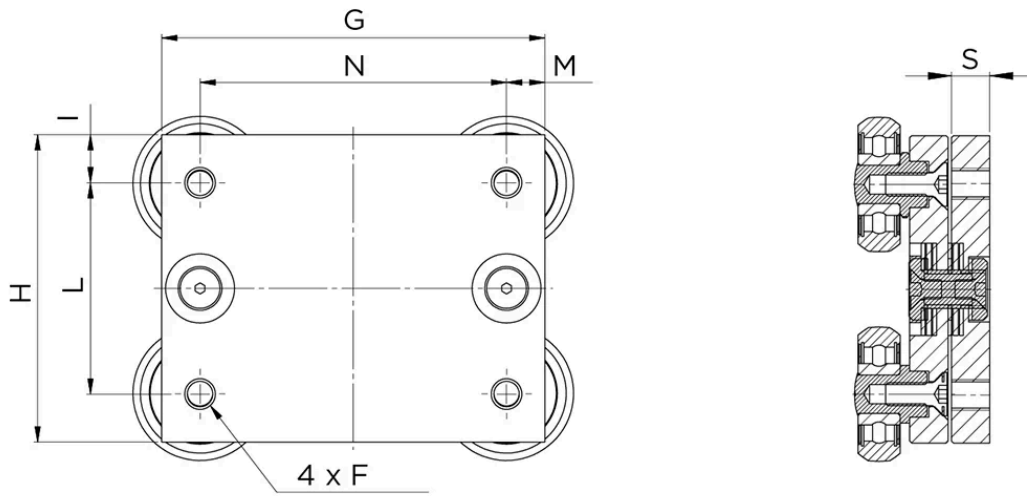

Designation	F	G	H	I	L	M	N	S
CCT08	M5	70	50	10	30	10	50	10
CCT11	M8	100	80	12.5	55	10	80	10