

Rail Type A

Corrosion resistant profiled rail, counterbore from above.

The aluminium profile rails are made of high quality aluminium alloy with rolled and precisely calibrated raceways made of stainless steel, X46Cr13 (1.4034) and are produced only in the accuracy class P. The use of aluminium achieves a weight saving compared to the steel types. It better compensates any unevenness in the mounting surface. The use of stainless steel for the track material, makes the rail corrosion resistant.

Due to the aluminium/steel composite construction, the rails should get ordered in the correct length. Only in exceptional cases it is allowed to cut it by yourself. Please insert rail lengths in mm after the designation when ordering. For example: A20-820.

Dimensions in mm.



General Data

Designation	Weight Rail (kg/m)	Length (mm)
A15	0.57	4000
A20	0.98	4000
A25	1.25	4000

Dimensions

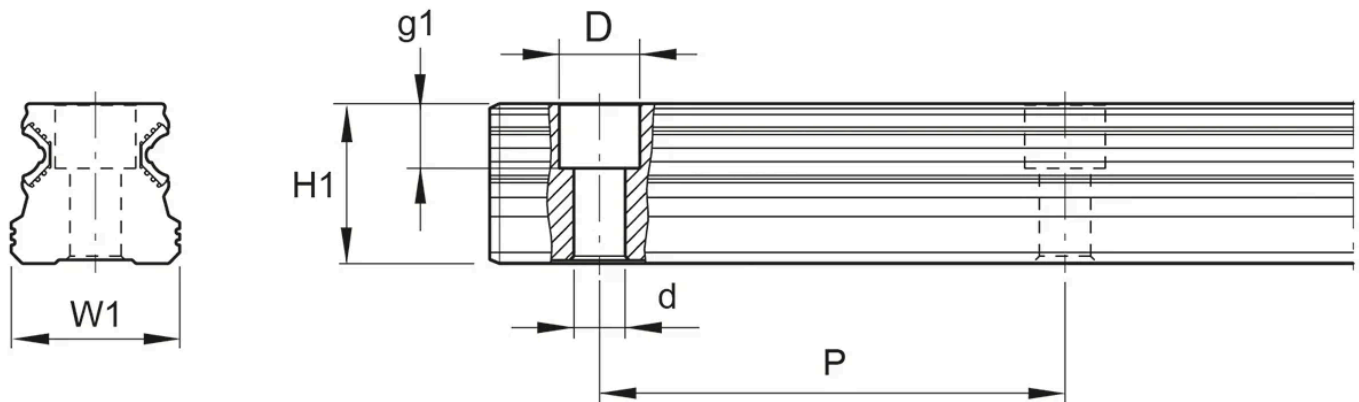

Designation	H1	W1	D x d x g1	Hole Pitch (P)
A15	14	15	7.5 x 4.4 x 5.9	60
A20	19	20	9.5 x 6 x 7.4	60
A25	21.8	23	11 x 7 x 8.9	60