

MR-M SS Series

Standard narrow rail type
End seal

This product is available in different preload and accuracy classes (see more in Technical Information). Please note that we do not have versions with all preload or accuracy classes on stock.

Dimensions in mm.

Please note that blocks and rails are not sold separately for sizes 2,3 and 5. Due to the small dimensions, blocks and sliders must be assembled and matched carefully to ensure correct quality and tolerances.

Lead times in the table below are only indications. Choice of preload, accuracy class and other options will affect lead time. Please contact us for exact delivery time for your request.

Material: Stainless steel



General Data

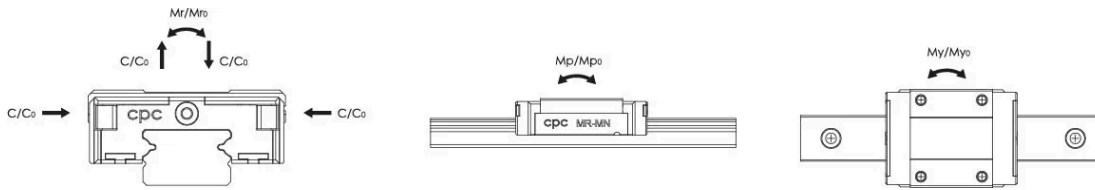

Designation	Dynamic Load Capacity C (N)	Static Load Capacity C0 (N)	Static Moment Mr0 (Nm)	Static Moment Mp0 (Nm)	Static Moment My0 (Nm)
MRU2MN-SU	158	349	0.43	0.54	0.54
MRU3MN-SS	190	310	0.6	0.4	0.4
MRU3ML-SS	295	575	0.9	1.1	1.1
MR5MN-SS	335	550	1.7	1	1
MR5ML-SS	470	900	2.4	2.1	2.1
MR7MN-SS	890	1440	5.2	3.3	3.3
MR7ML-SS	1310	2440	9	7.7	7.7
MR9MN-SS	1570	2495	11.7	6.4	6.4
MR9ML-SS	2135	3880	18.2	12.4	12.4
MR12MN-SS	2308	3465	21.5	12.9	12.9
MR12ML-SS	3240	5630	34.9	30.2	30.2
MR15MN-SS	3810	5590	43.6	27	27
MR15ML-SS	5350	9080	70	63.3	63.3

Designation	Dynamic Moment Mr (Nm)	Dynamic Moment Mp (Nm)	Dynamic Moment My (Nm)	Weight Block (g)
MRU2MN-SU	0.19	0.24	0.24	0.8
MRU3MN-SS	0.37	0.25	0.25	0.9
MRU3ML-SS	0.46	0.56	0.56	1.2
MR5MN-SS	1	0.61	0.61	3.5
MR5ML-SS	1.25	1.1	1.1	4
MR7MN-SS	3.2	2	2	8
MR7ML-SS	4.8	4.1	4.1	14
MR9MN-SS	7.4	4	4	18
MR9ML-SS	10	6.8	6.8	28
MR12MN-SS	14.3	8.6	8.6	34
MR12ML-SS	20.1	17.4	17.4	51
MR15MN-SS	29.7	18.4	18.4	61
MR15ML-SS	41.2	37.3	37.3	90

Dimensions

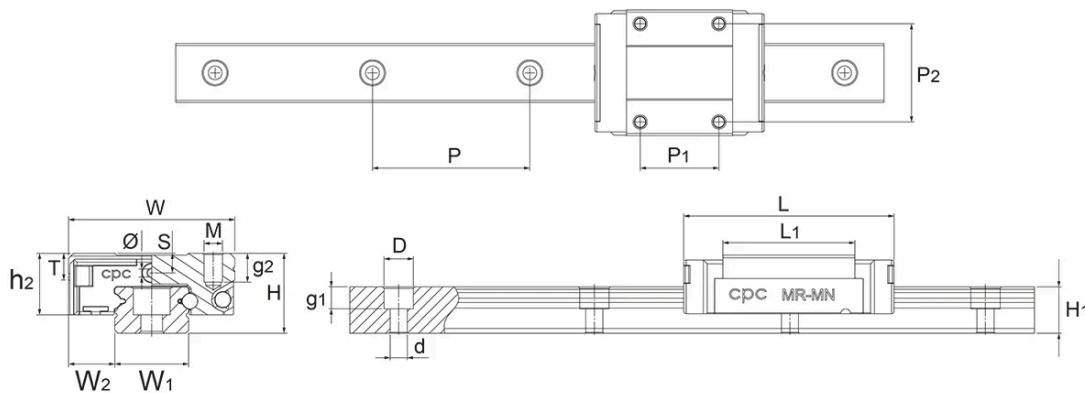

Designation	L	H	W	L1	H1	h2	W1	W2	S
MRU2MN-SU	12.5	3.2	6	8.8	2	2.6	2	2	-
MRU3MN-SS	11.9	4	8	6.7	2.6	3.2	3	2.5	0.7
MRU3ML-SS	16.1	4	8	11	2.6	3.2	3	2.5	0.7
MR5MN-SS	16.3	6	12	10	3.5	4.7	5	3.5	1.3
MR5ML-SS	19.7	6	12	13.5	3.5	4.6	5	3.5	1.3
MR7MN-SS	24.1	8	17	14.3	4.7	6.6	7	5	1.6
MR7ML-SS	31.5	8	17	21.8	4.7	6.7	7	5	1.6
MR9MN-SS	30.9	10	20	20.5	5.5	7.9	9	5.5	2.2
MR9ML-SS	41.1	10	20	30.8	5.5	8	9	5.5	2.2
MR12MN-SS	35.4	13	27	22	7.5	10.1	12	7.5	3.2
MR12ML-SS	47.8	13	27	34	7.5	10.2	12	7.5	3.2
MR15MN-SS	43.4	16	32	27	9.5	12.2	15	8.5	3.3
MR15ML-SS	60.2	16	32	44	9.5	12.2	15	8.5	3.3

Designation	T	D x d x g1	Hole Pitch (P)	M x g2	P1	P2	ø
MRU2MN-SU	-	M1	8	M1.4x1.1	4	-	-
MRU3MN-SS	1.5	M1.6	10	M1.6x1.1	3.5	-	0.3
MRU3ML-SS	1.5	M1.6	10	M2x1.1	5.5	-	0.3
MR5MN-SS	2	3.5 x 2.4 x 1	15	M2x1.5	-	8	0.7
MR5ML-SS	2	3.5 x 2.4 x 1	15	M2.6x2.0	7	-	0.7
MR7MN-SS	2.8	4.2 x 2.4 x 2.3	15	M2x2.5	8	12	1.1
MR7ML-SS	2.8	4.2 x 2.4 x 2.3	15	M2x2.5	13	12	1.1
MR9MN-SS	3.3	6 x 3.5 x 3.5	20	M3x3.0	10	15	1.3
MR9ML-SS	3.3	6 x 3.5 x 3.5	20	M3x3.0	16	15	1.3
MR12MN-SS	4.3	6 x 3.5 x 4.5	25	M3x3.5	15	20	1.3
MR12ML-SS	4.3	6 x 3.5 x 4.5	25	M3x3.5	20	20	1.3

Dimensions

Designation	T	D x d x g1	Hole Pitch (P)	M x g2	P1	P2	Ø
MR15MN-SS	4.3	6 x 3.5 x 4.5	40	M3x5.5	20	25	1.8
MR15ML-SS	4.3	6 x 3.5 x 4.5	40	M3x5.5	25	25	1.8